



**Manufacturer:**  
Amphenol Fiber Optic Products

**Product Name:**  
Amphenol SMA Adapter Metal Environmental Sealed D-Hole

**Manufacturer Part Number:**  
905-120-5008

▶ [Click here for more details on the Amphenol SMA Adapter Metal Environmental Sealed D-Hole](#)

**P/N: 905-120-5008**

**Description:** SMA, Standard Sealed Adapter (Coupler)



Amphenol Fiber Optic Products was the pioneer in developing the first industry standard fiber optic interconnect system by introducing the SMA connector & adapter. The 905 Series was the first fiber optic interconnect system to gain industry wide acceptance.

**Overview**

The Standard SMA Adapter, comes with Dust Caps, Lock Washer and Panel nut. The SMA adapters can be used with single and multi-mode fibers. The SMA adapter is an ideal way to extend cable length by joining two fiber optic cables together. The SMA Adapter has (2) counter-bores on the entry of the adapter, that allows O-ring compatible connectors to inter-connect. This O-ring will protect the connectors from dust and debris.



**Features & Benefits**

- Quality construction ensures long life, durability & dependability
- Bulkhead Feed-through type, D-Hole mounting
- Dust Caps protect against debris and contamination



**Applications**

- Medical / Surgical
- Laser Systems
- Industrial
- Spectrometers
- Data Communications

**Technical Specifications**

Adapter Side A	Threaded 1/4 x 36 2B UNS
Adapter Side B	Threaded 1/4 x 36 2B UNS
Fiber Type	Multi-Mode
Adapter Counterbores	Supports 906 connectors with O-ring compatibility
Environmentally Sealed	
Weight	.0083 Kg / .018 lbs

**Physical Characteristics**

SMA Adapter Body	Nickel Plated Brass
Nut	Nickel Plated Brass
Lockwasher	Stainless Steel
Dust Cap	Vinyl
Mounting Hole Recommendation	.281" x .125"
Gasket	Silicone
Length	23.50 mm / .925"

**Environmental Specifications**

Operating Temperature:	-40°C to 85°C
Storage Temperature:	-40°C to 70°C

**Contact the professionals at Fiber Optic Center for a quote or to get more details.**

[focenter.com](http://focenter.com) • 508-992-6464 | (800) 473-4237 • [sales@focenter.com](mailto:sales@focenter.com)

23 Centre Street • New Bedford, MA 02740 USA

Product specifications and data are subject to change without notice. FOC last update 3/1/2026.



**Manufacturer:**  
Amphenol Fiber Optic Products

**Product Name:**  
Amphenol SMA Adapter Metal Environmental Sealed D-Hole

**Manufacturer Part Number:**  
905-120-5008

▶ [Click here for more details on the Amphenol SMA Adapter Metal Environmental Sealed D-Hole](#)

**P/N: 905-120-5008**

**Assembly Drawing**

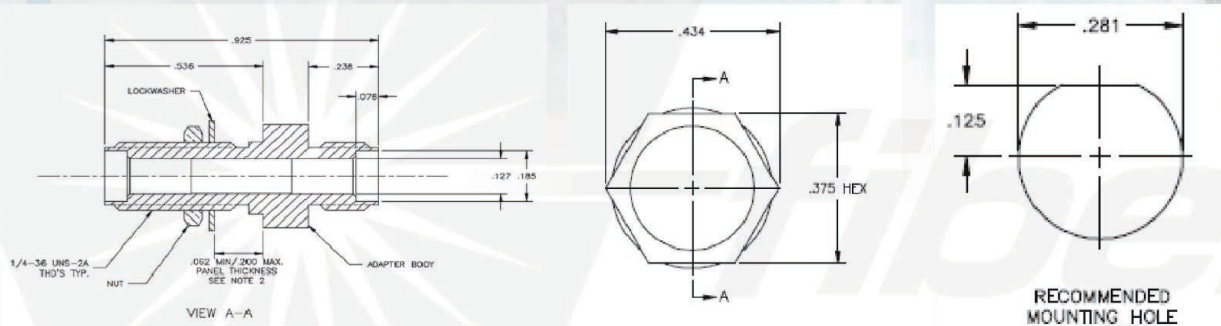

**Ordering Information**

Order Code:	Customization Options:	MOQ (Minimum Order Quantity):
905-120-5008-P	Individual Packaging Bulk Packaging (100)	300 Pieces

**Environmental Specifications**

Testing Method:	100% tested for optical performance
-----------------	-------------------------------------

**Compliance and Certifications**

IEC 61754-22 Compliant:	RoHS / Reach
-------------------------	--------------



**Contact the professionals at Fiber Optic Center for a quote or to get more details.**

[focenter.com](http://focenter.com) • 508-992-6464 | (800) 473-4237 • [sales@focenter.com](mailto:sales@focenter.com)

23 Centre Street • New Bedford, MA 02740 USA

Product specifications and data are subject to change without notice. FOC last update 3/1/2026.