



Manufacturer:
Amphenol Fiber Optic Products

Product Name:
Amphenol SMA Adapter Metal In-Line - Half Length

Manufacturer Part Number:
905-120-5004

▶ [Click here for more details on the Amphenol SMA Adapter Metal In-Line - Half Length](#)

P/N: 905-120-5004

Description: SMA, Half Length In-Line Adapter (Coupler)



Amphenol Fiber Optic Products was the pioneer in developing the first industry standard fiber optic interconnect system by introducing the SMA connector & adapter. The 905 Series was the first fiber optic interconnect system to gain industry wide acceptance.

Overview

The Standard SMA Adapter, comes with Dust Caps, Lock Washer and Panel nut. The SMA adapters can be used with single and multi-mode fibers. The SMA adapter is an ideal way to extend cable length by joining two fiber optic cables together.



Features & Benefits

- Quality construction ensures long life, durability & dependability
- Bulkhead Feed-through type, D-Hole mounting
- Dust Caps protect against debris and contamination



Applications

- Medical / Surgical
- Laser Systems
- Industrial
- Spectrometers
- Data Communications

Technical Specifications

Adapter Side A	Threaded 1/4 x 36 2B UNS
Adapter Side B	Threaded 1/4 x 36 2B UNS
Fiber Type	Multi-Mode
Weight	.01 oz

Physical Characteristics

SMA Adapter Body	Nickel Plated Brass
Hex Nut	Nickel Plated Brass
Lockwasher	Stainless Steel
Dust Cap	Vinyl
Mounting Hole Recommendation	6.4 mm
Length	11.3 mm / .445"

Environmental Specifications

Operating Temperature:	-40°C to 85°C
Storage Temperature:	-40°C to 70°C



Contact the professionals at Fiber Optic Center for a quote or to get more details.

focenter.com • 508-992-6464 | (800) 473-4237 • sales@focenter.com

23 Centre Street • New Bedford, MA 02740 USA



Manufacturer:
Amphenol Fiber Optic Products

Product Name:
Amphenol SMA Adapter Metal In-Line - Half Length

Manufacturer Part Number:
905-120-5004

▶ [Click here for more details on the Amphenol SMA Adapter Metal In-Line - Half Length](#)

P/N: 905-120-5004

Assembly Drawing

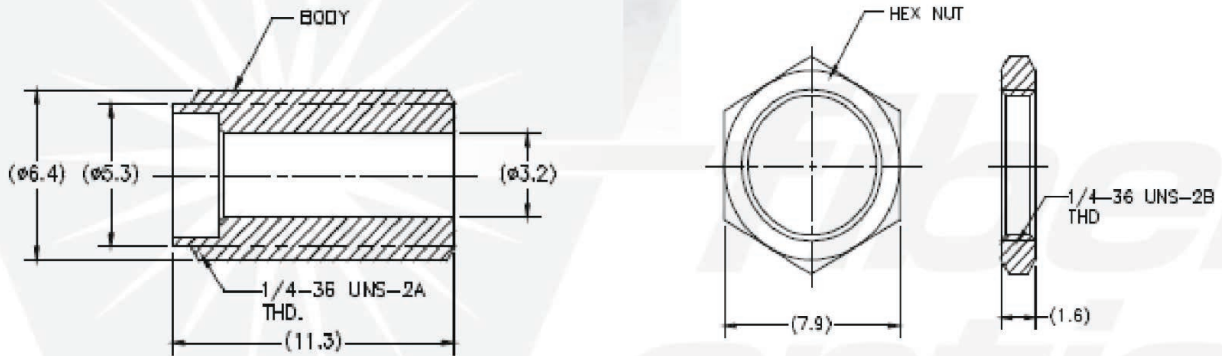

Ordering Information

Order Code:	Customization Options:	MOQ (Minimum Order Quantity):
905-120-5004-P	Individual Packaging Bulk Packaging (100)	300 Pieces

Environmental Specifications

Testing Method: 100% tested for optical performance

Compliance and Certifications

IEC 61754-22 Compliant: RoHS / Reach



Contact the professionals at Fiber Optic Center for a quote or to get more details.

focenter.com • 508-992-6464 | (800) 473-4237 • sales@focenter.com
23 Centre Street • New Bedford, MA 02740 USA