



Manufacturer:
Amphenol Fiber Optic Products

Product Name:
Amphenol SMA Screw or Bulkhead Mount Receptacle - SS

Manufacturer Part Number:
905-138-5010

▶ [Click here for more details on the Amphenol SMA Screw or Bulkhead Mount Receptacle - SS](#)

P/N: 905-138-5010

Description: Receptacle, SMA PC Mount, SS, with fully threaded holes



The SMA PC Mount Receptacle body is made of stainless steel with (2) fully threaded mounting holes. The screws and centering sleeves are shipped loose. Careful consideration must be reviewed as the Laser Diode tolerance range is very large.

Overview

The SMA PC Mount Receptacle comes with Dust Caps, Lock Washer, Panel nut, (2) #2-56 x 1/4 flat countersunk screws and centering sleeve

The SMA receptacle was designed to work with the following Laser Diodes.

1. TO-18 Laser Diode
2. TO-46 Laser Diode
3. SE-4352 or equivalent Laser Diode



Features & Benefits

- Quality construction ensures long life, durability & dependability
- Bulkhead Feed-through type, D-Hole mounting
- Dust Caps protect against debris and contamination



Applications

- Medical / Surgical
- Laser Systems
- Industrial
- Spectrometers
- Data Communications

Technical Specifications

Receptacle PC Mount	(2) 2-56 x 1/4 flat screws
Centering sleeve	POM
Laser Diode Receptacle	(3) Types
Weight	.01 oz

Physical Characteristics

Receptacle Body	Stainless Steel
Panel Nut	Nickel Plated Brass
Lockwasher	Stainless Steel
Dust Cap	Vinyl
Mounting Hole Recommendation	PC Mount
Length	15.16 mm / .596"

Environmental Specifications

Operating Temperature:	-40°C to 85°C
Storage Temperature:	-40°C to 70°C



Contact the professionals at Fiber Optic Center for a quote or to get more details.

focenter.com • 508-992-6464 | (800) 473-4237 • sales@focenter.com

23 Centre Street • New Bedford, MA 02740 USA



Manufacturer:
Amphenol Fiber Optic Products

Product Name:
Amphenol SMA Screw or Bulkhead Mount Receptacle - SS

Manufacturer Part Number:
905-138-5010

▶ [Click here for more details on the Amphenol SMA Screw or Bulkhead Mount Receptacle - SS](#)

P/N: 905-138-5010

Assembly Drawing

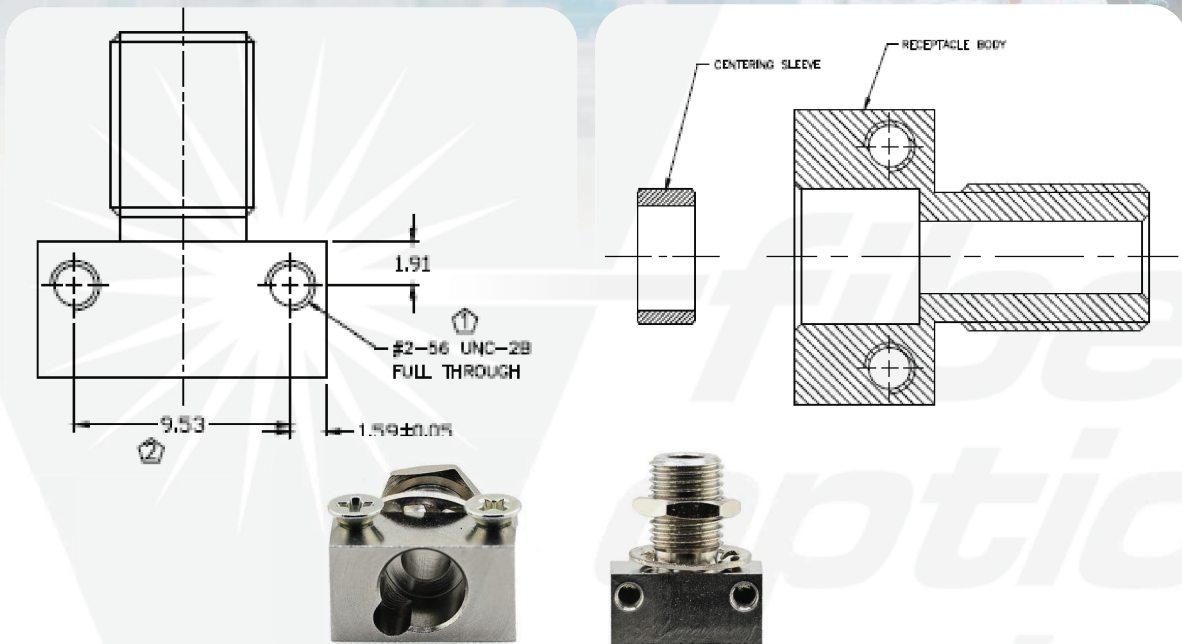

Note:

- When mounting this product, the key hole faces up and the screws mount through the PCB.
- This has threaded holes on both sides of the device which permits an alternative mount. It can either hang from a horizontal PCB or mount on top of the PCB. It is used with a LED.
- The 905-138-5010 in general is the preferred part over the 905-138-5009.

Ordering Information

Order Code:	Customization Options:	MOQ (Minimum Order Quantity):
905-138-5010	Individual Packaging Bulk Packaging (100)	300 Pieces

Environmental Specifications

Testing Method:	100% tested for optical performance
-----------------	-------------------------------------

Compliance and Certifications

IEC 61754-22 Compliant:	RoHS / Reach
-------------------------	--------------

Contact the professionals at Fiber Optic Center for a quote or to get more details.

focenter.com • 508-992-6464 | (800) 473-4237 • sales@focenter.com

23 Centre Street • New Bedford, MA 02740 USA