

USER GUIDE

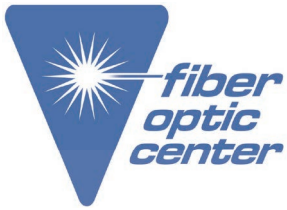

Manufacturer:
Dymax

Product Name:
Dymax 2000-EC UV Curing Flood Lamp

Manufacturer Part Number:
38105

▶ [Click here for more details on the Dymax 2000-EC UV Curing Flood Lamp](#)



[UV Light-Curing Flood Lamps User Guide](#)



[UV Light Shield User Guide](#)

Contact the professionals at Fiber Optic Center for a quote or to get more details.

focenter.com • 508-992-6464 | (800) 473-4237 • sales@focenter.com

23 Centre Street • New Bedford, MA 02740 USA

Product data subject to change without notice. FOC last update 2/18/2026.

USER GUIDE

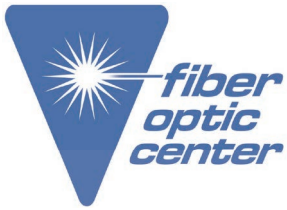

Manufacturer:

Dymax

Product Name:

Dymax 2000-EC UV Curing Flood Lamp

Manufacturer Part Number:

38105

▶ [Click here for more details on the Dymax 2000-EC UV Curing Flood Lamp](#)

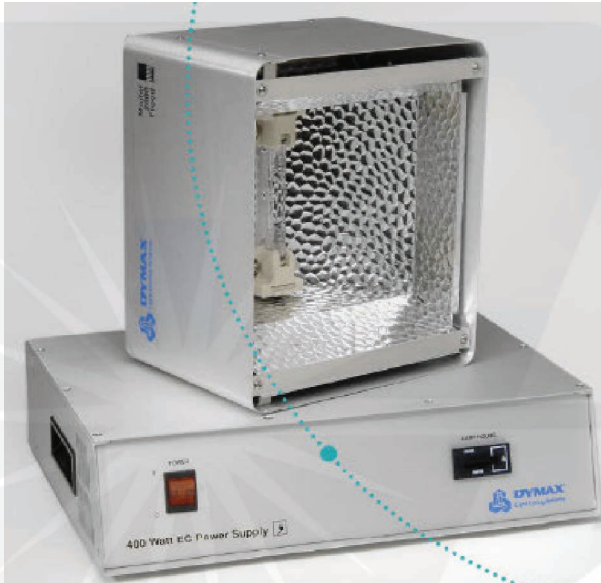

Silver EC-Series UV Light-Curing Flood Lamps User Guide



[>> Return to Page 1](#)

Contact the professionals at Fiber Optic Center for a quote or to get more details.

focenter.com • 508-992-6464 | (800) 473-4237 • sales@focenter.com

23 Centre Street • New Bedford, MA 02740 USA

Product data subject to change without notice. FOC last update 2/18/2026.

Contents

Introduction	4
Safety	4
General Safety Considerations.....	4
Specific Safety Considerations.....	5
Dymax UV Light-Curing System Safety Considerations	5
Product Overview	7
Description of the EC Series Flood Lamps	7
System Components.....	7
Assembly and Setup	9
Unpacking and Inspecting Your Shipment.....	9
Parts Included in an EC Flood Lamp	9
System Interconnection	10
Operation	11
Cleaning and Maintenance	12
Bulb Replacement Procedure.....	12
Lamp Base Replacement Instructions	13
Fuse Replacement Procedure	14
Cleaning.....	15
Preventing Unit Overheating.....	15
Troubleshooting	17
Spare Parts and Accessories	18
Accessories.....	19
Specifications	20
General Specifications.....	20
Electrical Specifications.....	21
Definition of Terms	22

>> Return to Page 1

Contact the professionals at Fiber Optic Center for a quote or to get more details.

focenter.com • 508-992-6464 | (800) 473-4237 • sales@focenter.com

23 Centre Street • New Bedford, MA 02740 USA

Product data subject to change without notice. FOC last update 2/18/2026.

Introduction

This guide describes how to assemble, use, and maintain a Dymax EC-series flood lamp system safely and efficiently.

Intended Audience

Dymax prepared this user guide for experienced process engineers, technicians, and manufacturing personnel.

Safety



WARNING! If you use a Dymax UV flood lamp system without first reading and understanding the information in this user guide, injury can result from exposure to UV light. To reduce the risk of injury, read and ensure you understand the information in this user guide before assembling and operating an EC-series flood lamp.

General Safety Considerations

All users of Dymax light-curing flood lamps should read and understand this user guide before assembling and using the system.

To learn about the safe handling and use of light-curable formulations, obtain and read the MSDS for each product.

Contact the professionals at Fiber Optic Center for a quote or to get more details.

focenter.com • 508-992-6464 | (800) 473-4237 • sales@focenter.com

23 Centre Street • New Bedford, MA 02740 USA

Product data subject to change without notice. FOC last update 2/18/2026.

Specific Safety Considerations

Dymax EC-series flood lamps are designed to maximize operator safety and minimize exposure to UV light-curing energy. To use the unit safely, it must be set up and operated in accordance with the instructions in this user guide. Please also read and understand the safety considerations unique to UV light-curing systems as described below.



WARNING! Looking directly at the UV light emitted by an EC flood lamp can result in eye injury. To prevent eye injury, never look directly at the high-intensity light and always wear protective goggles (provided).

Dymax UV Light-Curing System Safety Considerations

Operators must understand these four concepts to use the UV light source safely:

- UV exposure
- High-temperature surfaces
- Ozone
- Bright, visible light

Each is described below.

UV Exposure

Standard Dymax UV light-curing systems and bulbs have been designed primarily to emit UVA light (**Error! Reference source not found.**). UVA light is generally considered the safest of the three UV ranges: UVA, UVB, and UVC. Although OSHA does not currently regulate ultraviolet light exposure in the workplace, the American Conference of Governmental Industrial Hygienists (ACGIH) does recommend Threshold Limit Values (TLVs) for ultraviolet light.

The strictest interpretation of the TLV (over the UVA range) for workers' eyes and skin is 1 mW/cm² (intensity), continuous exposure. Unless workers are placing bare hands into the curing area, it is unusual to exceed these limits. To put 1 mW/cm² limit into perspective, cloudless summer days in Connecticut regularly exceed 3 mW/cm² of UVA light and also include the more dangerous UVB light (primarily responsible for sun tans, sun burns, and skin cancer) as well.

Figure 1.
Spectrum of Light

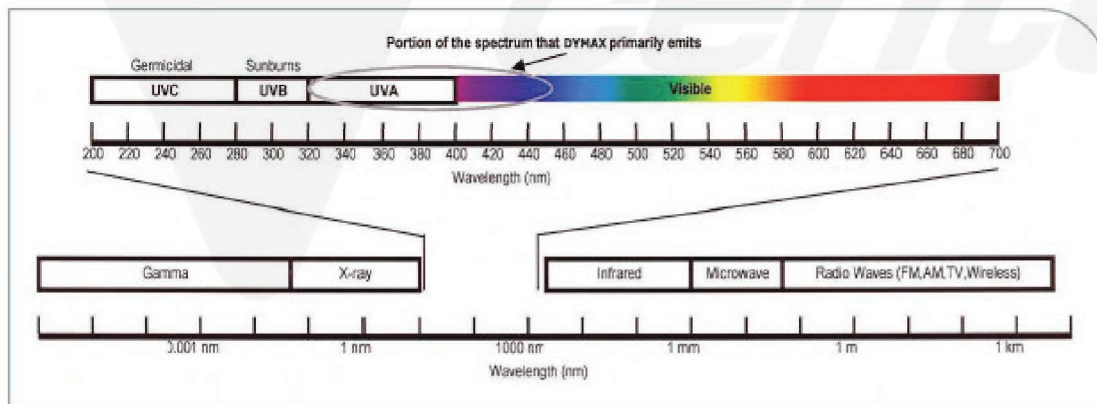

Contact the professionals at Fiber Optic Center for a quote or to get more details.

focenter.com • 508-992-6464 | (800) 473-4237 • sales@focenter.com

23 Centre Street • New Bedford, MA 02740 USA

Checking the Workstation

The human eye cannot detect “pure” UV light, only visible light. A radiometer should be used to measure stray UV light to confirm the safety of a UV light-curing process. A workstation that exposes an operator to more than 1 mW/cm² of UVA continuously should be redesigned.

Protecting Operators

Light-curing technology can be a regulatory compliant, “worker-friendly” manufacturing process when the proper safety equipment and operator training is utilized. There are two ways to protect operators from UV exposure: shield the operator and/or shield the source.

Shield the Operator — UV-Blocking Eye Protection - UV-blocking eye protection is recommended when operating UV light-curing systems.

UV-Blocking Skin Protection — Where the potential exists for UV exposure upon skin, opaque, UV-blocking clothing, gloves, and full-face shields are recommended.

Shield the Source of UV

Any substrate that blocks UV light can be used as a shield to protect workers from stray UV light. The following materials can be used to create simple shielding structures:

Rigid Plastic Film — Transparent or translucent/UV-blocking plastics (typically polycarbonate or acrylic) are commonly used to create shielding where some level of transparency is also desired.

Flexible Film — Translucent UV-blocking, flexible urethane films can be used to quickly create workstation shielding.

Ozone

Standard Dymax bulbs (UVA type) generate an insignificant amount of UVC and therefore essentially no ozone. Some UV light-curing systems, like those used to cure UV inks, emit primarily “shortwave” (UVB and UVC) energy. Upon exposure to UVC light (specifically <240 nm), oxygen molecules (O₂) split into oxygen atoms (O) and recombine with O₂ to create ozone O₃. The current, long-term ozone concentration limit recommended by ACGIH, NIOSH, and OSHA is 0.1 ppm (0.2mg/m³).

High-Temperature Surfaces

Surfaces exposed to high-intensity curing lights will rise in temperature. The intensity, distance, exposure time, cooling fans, and the type/color of the surface can all affect the actual surface temperature. In some cases, exposed surfaces can reach temperatures capable of producing a burn or causing damage to a substrate. In these cases, care must be taken to ensure either a more moderate surface temperature or appropriate protection/training for operators.

Bright, Visible Light

The bright, visible light emitted by some UV light-curing systems can be objectionable to some workers and can cause eyestrain. Tinted eye protection and/or opaque/tinted shielding can be utilized to address this concern.

Summary

UV-light sources can be more “worker friendly” than many commonly accepted industrial processes, provided the potential concerns are addressed. Both the lower working temperature and lack of spurious frequency transmission that this system

Contact the professionals at Fiber Optic Center for a quote or to get more details.

focenter.com • 508-992-6464 | (800) 473-4237 • sales@focenter.com

23 Centre Street • New Bedford, MA 02740 USA

produces make it even more user friendly.

Product Overview

Description of the EC Series Flood Lamps

Dymax EC-Series Flood Lamps are general-purpose curing units used to cure UV light-curable adhesives, coatings, and inks. These light sources are exceptionally versatile and expandable, allowing them to be utilized in an array of manufacturing situations and applications, including bonding, potting, sealing, and encapsulating.

Each unit is designed and shipped in a unitized configuration for easy bench-top mounting. These flood lamps can also be custom configured so the Lamp/Reflector Assembly Housing can be mounted in a remote curing location away from the Power Supply. Several Lamp/Reflector Assembly Housings can be mounted side-by-side in a linear configuration (such as on conveyor systems) or a large area array. The Power Supplies can then be stacked and mounted remotely to provide consolidated operator control. The Lamp/Reflector Assembly Housings are designed with clean, unobstructed surfaces making them easy to install in existing or specialized equipment.

System Components

Flood Lamps

1200-EC

The Dymax 1200-EC is a focused-beam UV Light-Curing Lamp used for the curing of UV light-curable adhesives, coatings, and inks. The unit's elliptical Reflector provides an intense 1" x 6" area of UV energy 4.5" away from the lower edge of the Lamp/Reflector Assembly Housing.

The 1200-EC employs convection cooling. An optional Fan Ventilation Kit is available to remove excessive heat and ventilate curing vapors away from the Lamp/Reflector Assembly Housing. Refer to the spare parts/options section of this manual for more information on the Fan Ventilation Kit.

2000-EC

The Dymax 2000-EC is a general-purpose UV Light-Curing Flood Lamp with an effective curing area of approximately 8" x 8", making it ideal for batch processing or curing large areas.

An optional special Glass UV Filter may be installed in the 2000-EC Reflector to reduce UV-B and UV-C spectral emissions. When operated correctly using the Glass UV Filter, extensive shielding associated with many Lamps can be minimized.

The 2000-EC employs convection cooling. An optional Fan Ventilation Kit is also available. This kit removes excessive heat due to the Lamp's possible proximity to other heat sources, or to remove vapors from under the Lamp/Reflector Assembly Housing during curing of UV light-curable materials. Refer to the spare parts/options section of this manual for more information on the Fan Ventilation Kit.

5000-EC

The Dymax 5000-EC is a general-purpose UV Light-Curing Flood Lamp with an effective curing area of approximately 5" x 5". It is ideal for small batch processing of UV adhesives and potting compounds.

Comparatively, it provides more than twice the output intensity of a 2000-EC Flood Lamp for faster curing capability and the additional ability to cure conformal coating resins.

Contact the professionals at Fiber Optic Center for a quote or to get more details.

focenter.com • 508-992-6464 | (800) 473-4237 • sales@focenter.com

23 Centre Street • New Bedford, MA 02740 USA

Figure 2.
Lamp/Reflector Housings (Left to Right: 1200-EC, 5000-EC, & 2000-EC)



Solid-State Power Supply

The Solid-State Power Supply allows external electrical inputs and provides power to the Lamp. The front panel contains the On/Off Power Switch and Hour Meter. The Power Supply also houses its own Cooling Fan and power distribution for optional accessories. The rear panel has an integrally fused AC-Power Receptacle and an 8-pin female Amp Connector.

The Power Supply yields reliable and stabilized Lamp voltage in virtually any electrical system in the world. Other than ensuring a properly configured plug is employed, no other adjustment of settings is required. The Power Supply also conditions the electrical power to the Lamp providing longer, more reliable Lamp life.

Figure 3.
EC-Series Power Supply



Contact the professionals at Fiber Optic Center for a quote or to get more details.

focenter.com • 508-992-6464 | (800) 473-4237 • sales@focenter.com

23 Centre Street • New Bedford, MA 02740 USA

Assembly and Setup

Unpacking and Inspecting Your Shipment

When your flood lamp arrives, inspect the boxes for damage and notify the shipper of box damage immediately.

Open each box and check for equipment damage. If parts are damaged, notify the shipper and submit a claim for the damaged parts.

Check that the parts included in your order match those listed below.

Parts Included in an EC Flood Lamp

- **Reflector Assembly Housing (1)** – Contains lamp sockets, a high-voltage starter, three circular connectors, and one reflector (1200, 2000, or 5000) with an UV lamp (400-Watt, metal halide. Optional visible or mercury vapor bulbs available).
- **UV Glass Filter for the 2000-EC (2)** – Optional
- **Solid-State Power Supply (3)**
- **Interconnection Cable (5)** – Connects the power supply to the lamp/reflector assembly housing.
- **Power Cord (4)** – North American power cord shown
- **UV Protection Goggles (6)**
- **Hex Wrench (7)**
- **Dymax EC-Series UV Flood Lamps User Guide (8)**

Figure 4.
EC Series Flood Lamp Unpacking Diagram

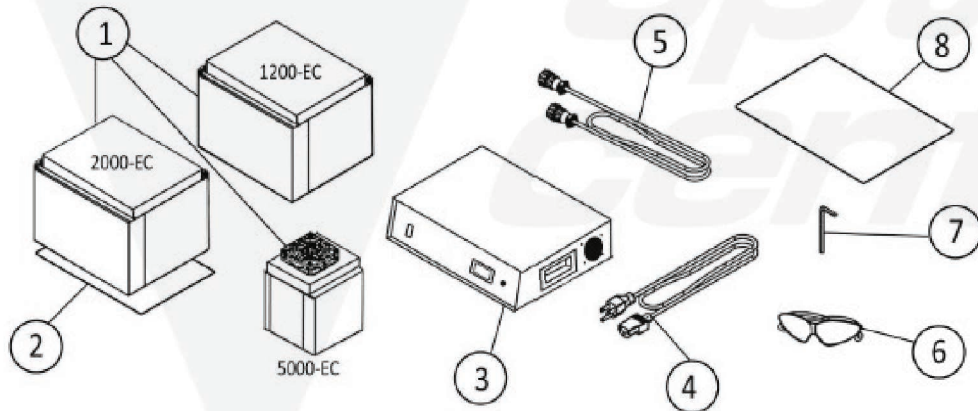

Contact the professionals at Fiber Optic Center for a quote or to get more details.

System Interconnection

Figure 5.
Interconnection Diagram

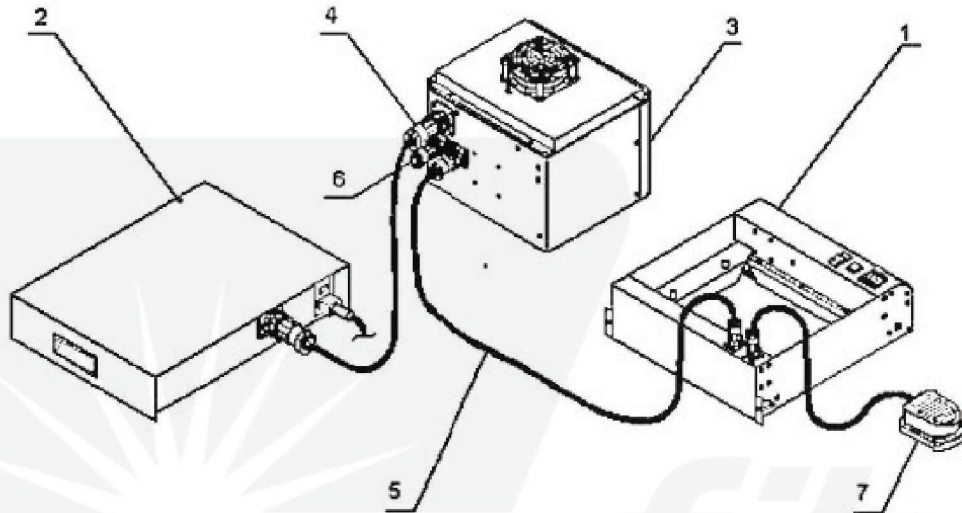

#	Part Description	#	Part Description
1	Shutter, Optional	5	Shutter Interconnect Cable, Optional
2	Power Supply (8-Pin Connector)	6	Plug, Adapter, Optional
3	Reflector (8-Pin Connector)	7	Foot Pedal, Optional
4	8-Pin to 8-Pin Interconnect Cable		

1. Place the 400 Watt Bulb into the Lamp/Reflector Assembly Housing. Refer to the Bulb Replacement/ Installation section of this manual.
2. A Glass UV Filter is available as an option. This Glass UV Filter reduces heat produced by Lamp but will also reduce UV output of Reflector. To install the optional Glass UV Filter (sold only for the 2000-EC Flood Lamp):

NOTICE: It is important to wear protective gloves when installing the Glass UV Filter! Do not touch the Filter with bare fingers! Fingerprints may etch into glass and cause light transmission loss!

- Place the Reflector Housing upside down on a flat surface.
 - Loosen the four screws in the bracket that hold the Reflector to the Housing.
 - Slide the Glass UV Filter under the brackets and adjust it symmetrically over the Reflector Aperture.
 - Tighten the four screws.
3. Locate the Power Supply and Reflector Housing so that there is free air circulation around sides. The Reflector may be mounted to a Dymax Flood Lamp accessory such as a Mounting Stand, Light Shield, or Shutter. See the connecting instructions in the operation manual for the appropriate Dymax accessory.

Contact the professionals at Fiber Optic Center for a quote or to get more details.

focenter.com • 508-992-6464 | (800) 473-4237 • sales@focenter.com

23 Centre Street • New Bedford, MA 02740 USA

WARNING! Always observe safety requirements when working with electrical equipment! Electrical hazard is present!

4. Secure the Reflector Housing in the designated operation location.
5. Connect the Interconnect Cable to the J3 Receptacle on the Reflector Housing (coded red, Figure 6).

NOTE: Cables and receptacles are coded with color dots to assist in the installation of cables. Connections may vary if using a Dymax Flood Lamp accessory such as a Mounting Stand, Light Shield, or Shutter. See the connecting instruction in the operation manual for the appropriate Dymax accessory.

6. Connect the opposite end of the Interconnect Cable to the Lamp Power Receptacle on rear panel of the Power Supply (coded red).
7. Make sure that the other Dymax accessories, if any, are also properly connected and operational.
8. Plug the Power Cord into the Power Module located in the rear panel of the Power Supply (Figure 7) and plug the other end of the Power Cord into an external AC source.

Figure 6.
J3 Receptacle



Figure 7.
Power Module



Operation

Turn the unit on by pressing on the Power Switch (located to the left on front of the Power Supply panel). The switch will light up to indicate that the power is on.

NOTE: While most Lamps typically require less than 30 seconds to ignite, a new Lamp will sometimes require several minutes.

After the Lamp has ignited, allow five minutes for the Lamp to reach its maximum output intensity.

Lamp life is reduced approximately one hour each time it is started. To avoid premature Lamp deterioration, leave the unit on through breaks, short shutdowns, and lunch hours.

These UV Flood Lamps are designed for continuous operation.

Contact the professionals at Fiber Optic Center for a quote or to get more details.

focenter.com • 508-992-6464 | (800) 473-4237 • sales@focenter.com

23 Centre Street • New Bedford, MA 02740 USA

NOTE: If the power is momentarily lost or the Lamp is inadvertently shut off, it must cool down before restarting. This may take 5-10 minutes depending on ambient conditions. The Power Supply may be left energized while the Lamp is cooling. The Lamp will re-light when it has cooled sufficiently.

Each time the Lamp is turned on, it should operate for at least five minutes to allow complete ionization of elements inside the Lamp. Failure to do this may result in failure of the Lamp to restart. Refer to the troubleshooting section of this manual for more information.

Cleaning and Maintenance

Bulb Replacement Procedure

1. Every new EC-Series Flood Lamp is supplied with a new 400-Watt Bulb. When the Bulb requires replacement, the following procedure must be followed.
2. Turn the Power Switch off and disconnect the Power Supply from the electrical power source. Allow the Bulb to cool.

CAUTION: The Bulb operates at temperatures exceeding 500°C. Touching the Bulb before sufficient cool down time is allowed will cause severe burns. Always wear safety eye wear while replacing Bulb.

3. Hold the Lamp/Reflector Assembly Housing securely and loosen the thumbscrew on the Lamp/Reflector Assembly Housing Bracket. Lift the housing off the Mounting Stand and place upside down on a clean work surface.
4. Remove the Glass UV Filter (if installed in the 2000-EC) by removing one Retaining Strap held by two (2) 8-32 x 3/8" button-head screws with a 3/32 hex wrench. If the optional Glass UV Filter is installed, loosen the two (2) 8-32 x 3/8" button-head screws in the remaining Retainer Strap so that the Glass UV Filter can slide out.
5. Reach into the Reflector and grasp the flat area of Bulb at either end.

CAUTION: Always use a soft, clean rag, clean paper towel, or gloves when handling the Bulb. Skin oils left on the Bulb will burn into the quartz, reducing output intensity. If the Bulb is inadvertently touched, clean the Bulb thoroughly with a soft, clean rag and alcohol.

Figure 8.
Bulb in Reflector

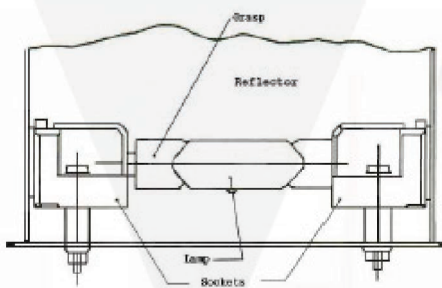

6. Lightly push the Bulb toward the Socket on the opposite end of the Lamp so that the end being grasped can be lifted clear of the Socket (Figure 9).

Contact the professionals at Fiber Optic Center for a quote or to get more details.

focenter.com • 508-992-6464 | (800) 473-4237 • sales@focenter.com

23 Centre Street • New Bedford, MA 02740 USA

Figure 9.
Bulb Removal

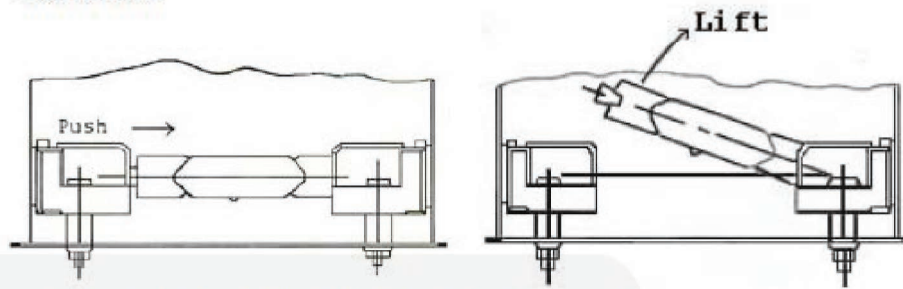

7. Install the new Bulb by following Steps 5, 6, and 7 in the reverse order.

IMPORTANT: Install the Bulb such that the seal dimple on the bulge of the glass is facing towards the Reflector surface. Avoid touching the quartz tube with your fingers.

NOTE: Bulb has no polarity.

8. Record the serial number of the unit and the hour-meter reading in the Bulb History Record.
9. Replace the Lamp/Reflector Assembly Housing on the Mounting Stand by engaging the Mounting Bracket.
10. Secure the thumbscrew when the Lamp/Reflector Assembly Housing is at the proper height.
11. Reconnect the Power Cord to the appropriate power source.
12. Turn the Power Switch on and allow the Lamp to warm up for five minutes before using.

NOTE: If the Lamp does not ignite, refer to the trouble-shooting section of this manual.

Lamp Base Replacement Instructions

1. Turn off the power.
2. Remove the Power Cord and Interconnect Cord from the unit.
3. Remove the Lamp/Reflector Assembly from the Mounting Stand and place it on a clean, flat surface with the Lamp facing up.
4. Remove the Lamp (refer to Lamp Replacement Procedure).
5. Remove the Lamp/Reflector Assembly from the housing by removing the four screws, two on each side, from the Reflector.
6. Remove the two screws from the side of the unit, holding the Igniter in place (located inside a blue fireproof sleeve) and remove from the sleeve.
7. Loosen the screws and remove the wires from the Igniter at locations marked "N" and "La". The black PTFE wire at location "N" will have to be clipped from the Lamp Base Wire and re-stripped.
8. Remove both Lamp Bases and install the new Lamp Bases from the Lamp Base Replacement Kit.

Contact the professionals at Fiber Optic Center for a quote or to get more details.

focenter.com • 508-992-6464 | (800) 473-4237 • sales@focenter.com

23 Centre Street • New Bedford, MA 02740 USA

9. Take one of the Lamp Bases and crimp on a supplied terminal (PN 35202). This wire will be installed in the "La" location on the Igniter.
10. The remaining Lamp Base Wire will be joined with the black PTFE wire using the supplied terminal (PN 35218). This wire will be installed in the "N" location on the Igniter.
11. Place the Igniter back into the blue fireproof sleeve and fasten to the side of the Housing using the two screws that had been removed in Step 6.
12. Place the Reflector back into the Housing and fasten with the four remaining screws.
13. Place the Lamp back into the unit.

Fuse Replacement Procedure

The EC-Series 400-Watt Power Supply utilizes two Line-Input Fuses. These Fuses are external and are located in the Power Cord Receptacle at the rear of the Power Supply Housing. They are 6.25 Amp, slow-blow Fuses.

WARNING! Electrical shock hazard. Exercise extreme care when replacing Fuses. Make sure only qualified personnel perform Fuse replacement and that all Power Switches are off and the Power Cord is unplugged.

Replacing External Fuses

1. Turn the Power Switch on the Power Supply off.
2. Unplug the Power Cord from the electrical source.
3. Unplug the Power Cord from the Power Cord Receptacle at the rear of the Power Supply Housing.
4. Place a small, flat-blade screwdriver into the notch at the top of the Plug Recess and pull the Fuse Cover downwards approximately 70°. The Fuse Retainer should be exposed and should be removed by pulling it straight out (Figure 10).

Figure 10.
Replacing Fuses in the Power Supply



5. Slide out the blown Fuses and replace with new 6.25 Amp, slow-blow Fuses.
- CAUTION:** It is important to replace this Fuse with the same 6.25 Amp rated, slow-blow type Fuse.
6. Slide the Fuse Cover back into the Receptacle until it is fully seated, then rotate the cover upward until it latches.
 7. Install the Power Cord and connect it to the electrical power source.
 8. Turn the Power Switch on.

Contact the professionals at Fiber Optic Center for a quote or to get more details.

focenter.com • 508-992-6464 | (800) 473-4237 • sales@focenter.com

23 Centre Street • New Bedford, MA 02740 USA

Cleaning

Periodically remove and clean the optional Glass UV Filter if installed. Follow Step 5 in the Bulb Replacement Procedure for removal. Clean with any standard glass cleaner or use isopropyl alcohol for heavy deposits. Reinstall the Glass UV Filter by following Step 2 of the Installation Procedure.

NOTE: The optional Glass UV Filter for the 2000-EC loses its ability to transmit UV over time. This is due to “solarization” of the glass caused by the intense UV radiation. Cleaning can extend the useful life of the Filter, but its transmission should be monitored periodically and replaced as necessary.

Failure to regularly clean the Glass UV Filter will result in reduced UV output to the resin being cured, thereby increasing the time required to achieve optimum cure.

Periodically clean the Bulb and Reflector surfaces. A soft, clean cloth and any standard glass cleaner should be used. Heavier deposits may require cleaning with isopropyl alcohol.

CAUTION: Cleaning the Reflector with a rough or dirty cloth will result in a dulled surface, thereby reducing reflectance and decreasing UV output. Use only a soft, clean cloth.

Any uncured resins spilled onto the Flood Lamp can be removed with isopropyl alcohol and a clean cloth.

Preventing Unit Overheating

Dymax EC-Series UV-Curing Flood-Lamp models do not possess an automatic shut-off capability in the event of the Lamp Reflector Assembly overheating. The Ignitor within an EC Lamp Reflector Assembly, under certain conditions, may overheat to a point where the Ignitor itself can melt, char, or smoke if the unit continues to operate while in an overheated condition. Adjacent materials and components, such as fiberglass insulation and insulated wiring, may show heat and/or smoke associated discoloration or degradation. The following checks will reduce the risk of overheating Ignitors within the Lamp Reflector Assembly:

1. Replace Bulbs at the recommended 2,000-hour service intervals, or before the intensity falls outside of the application requirements. A degraded or damaged Bulb increases the risk of arcing, or can create an excessive current draw on the Ignitor which can raise the internal temperature of the Ignitor.
2. Dymax recommends that only Dymax-branded OEM Bulbs be used in the EC Lamp Reflector Assemblies. Some after-market or inferior quality Bulbs are built to different specifications which may deteriorate more rapidly, leading to an increased burden on the Ignitor, and associated internal temperature increase of the Ignitor.
3. Confirm that the Bulb orientation is correct, and has been properly seated into the Lamp Sockets.

A secure Bulb should not move freely in the Lamp Base. Lightly try to move the Bulb laterally, longitudinally, and rotationally to ensure the Bulb contact areas are fully seated with the Socket contacts.

NOTE: Always use a soft, clean lint free towel, clean paper towel, or gloves when handling the Bulb. Skin oils left on the Bulb will burn into the quartz, reducing output intensity. If the Bulb is inadvertently touched, clean the Bulb thoroughly with a soft, clean lint free towel and alcohol. Refer to the user manual enclosed within the unit for complete instructions.

4. Inspect Lamp Sockets for any signs of arcing, physical, or heat-related damage, and replace if needed. Inspect closely, as the Lamp Sockets are ceramic and may have a hairline crack that may not be noticeable from afar.

Contact the professionals at Fiber Optic Center for a quote or to get more details.

focenter.com • 508-992-6464 | (800) 473-4237 • sales@focenter.com

23 Centre Street • New Bedford, MA 02740 USA

On the 5000-EC, the Lamp Socket is partially hidden by the Reflector material. The Reflector may be removed by the 4 Screws on the bottom of the unit to allow for a more detailed inspection.

5. As with any machinery or equipment, general preventive maintenance should be performed to ensure the equipment continues to perform as intended. Wear components, such as Fans and Lamp Socket Assemblies, should be replaced routinely.
 - Lamp Socket Assemblies should be replaced every 4 Bulb changes.
 - Fans should be replaced every 5 years or 50,000 hours of ON time.

For severe duty applications (e.g. units that are running under 24/7 operating conditions, or harsh ambient condition), replacements should be considered every 4 years, or 40,000 hours. |

6. Ensure that the Fan, on any fan-equipped model, is operating while the Lamp is in use.
 - If the Fan is not spinning, check to ensure that all electrical connections to the Reflector Head are secure and the Fan is getting power to run.
 - Confirm that the Fan is free of debris or contamination that could restrict air flow. Visible debris should be cleaned and removed.
 - With the power turned OFF, check to ensure the Fan Blades can rotate freely.
7. For models without Fans, the unit relies on natural convection for cooling. The recommended installation is an upright position (energy emissions facing downward), to allow rising hot air to escape freely. Optional provisions for horizontal mounting can be acceptable, but inverted Lamps should be avoided.

The installation requires unrestricted airflow in accordance to the user manual to minimize/eliminate entrainment and recirculation of hot air.

8. For EC units mounted on Conveyor Systems, ensure that the Conveyor Exhaust Blower is operating and adjusted properly to provide the sufficient air flow and cooling to the Lamps.

Ensure that there is at least 6" of open space around all surfaces of the head, and that airflow is unrestricted to the top and bottom sides.

9. Measure and check the temperature of the EC unit's outside sheet-metal surface to ensure the temperature is in the range of 115°F to 145°F. If the temperature is exceeding this value range, it may be an indication that the unit's operating environment is not suitable, or the equipment requires further inspection of components.

Temperature strips (PN 38694) can be purchased and adhered to the top side of unit if instrumentation to measure directly is not available to the user.

Contact the professionals at Fiber Optic Center for a quote or to get more details.

focenter.com • 508-992-6464 | (800) 473-4237 • sales@focenter.com

23 Centre Street • New Bedford, MA 02740 USA

Troubleshooting

NOTE: Only qualified maintenance personnel should attempt the following procedures.

Problem	Possible Cause	Testing	Corrective Action
Lamp Will Not Ignite or Lamp Flickers, Won't Maintain Operation	Improperly fastened connections	Visually inspect all connections to and from the Power Supply.	Secure all connections.
	Main Line Fuses blown	Remove Fuses from Power Receptacle and check with an Ohmmeter.	Replace Fuses, if defective.
	Corroded Lamp Bases	Visually inspect the Lamp Bases for any signs of corrosion.	Replace the Lamp Bases if corrosion exists (both Lamp Bases should be replaced at the same time).
Lamp Flickers, Won't Maintain Operation	Bulb beyond its useful life	Replace the Bulb with a Bulb that is good and re-test unit.	Replace the Bulb if defective (typical Bulb life = 2,000 hours).
	Power Supply Board failed	Check the output voltage on the Power Supply Board. Set the Oscilloscope to: 20 ms/div 100 V/div	Expected value 290-340 V/rms Square Wave. Replace the Power Supply Board if defective.
	Ignitor malfunctioned	Verify open circuit voltage from Ignitor. Set the Oscilloscope to: 50 us/div 1000 V/div	Expected value 4-5 KV ignition pulse superimposed on the square wave. Replace if defective.
Unit Blows Input Fuse	Malfunction in the Power Supply Board	Remove power. Disconnect the Lamp/Reflector Assembly from the Power Supply. Replace the Fuse. Apply power. If a Fuse blows, the Power Supply is defective.	Replace the Power Supply Board.
UV Intensity Appears to Be Low	Bulb beyond its useful life	Use a Radiometer (ACCU-CAL™ 50) to measure actual output intensity. Consult manual for proper output.	Replace the Bulb if beyond the useful life (typical life = 2,000 hours).
	Quartz Envelope on Bulb contaminated	Visually inspect the Bulb for signs of contamination (Quartz Envelope must be free from any contamination).	Clean the Bulb with a soft, lint-free cloth and isopropyl alcohol. Bulb may have to be replaced if contamination is burned into Quartz Envelope.
	Surfaces of Reflector may be contaminated	Examine reflector surface for contaminants (should be a clean, shiny surface).	Clean the Reflector with a soft, lint-free cloth and isopropyl alcohol or an equivalent.
	Optional Glass UV Filter contaminated (2000-EC only)	Examine the Glass UV Filter for signs of contamination.	Clean the Glass UV Filter with a soft, lint-free cloth and isopropyl alcohol or an equivalent.

Contact the professionals at Fiber Optic Center for a quote or to get more details.

focenter.com • 508-992-6464 | (800) 473-4237 • sales@focenter.com

23 Centre Street • New Bedford, MA 02740 USA

Spare Parts and Accessories

Item	Part Number
Fuses	
Fuse, F 6.25 Amp	35141
Personal Protection Equipment	
Protective Goggles — Clear	35612
Protective Goggles — Gray	35285
Lamps	
Lamp, Metal Halide 400 Watt UV (Standard)	38560
Lamp, Mercury Vapor 400 Watt UV (Optional)	36970
Lamp, Visible 400 Watt (Optional)	36658
Lamp Base Replacement Kits	35979
Miscellaneous	
Optional Fan Assembly (2000-EC, 1200-EC)	38300
Optional Glass UV Filter (2000-EC Only)	35899
Power Switch	36288
Repair Kit, EC Silver Power Supply	41096
Stands	
Mounting Stand Kit for the 5000-EC	38289
Mounting Stand Kit for the 1200-EC & 2000-EC	38290

Contact the professionals at Fiber Optic Center for a quote or to get more details.

focenter.com • 508-992-6464 | (800) 473-4237 • sales@focenter.com

23 Centre Street • New Bedford, MA 02740 USA

Accessories

Several optional accessories are available to enhance efficiency and operation of Dymax EC-Series UV Light-Curing Flood Lamps.



UV Radiometer (PN 39561)

Dymax offers an ACCU-CAL™ 50 for monitoring the UV intensity of the EC-Series Flood Lamps. This Radiometer is calibrated to measure UVA output (320-390 nm) wavelength.

Features include:

- Auto ranging, digital readout (1.0 to 40,000 mW/cm²)
- Measures light intensity in mW/cm²
- Powered by AA batteries (included)
- Stores in molded plastic case (included)



Top Ventilation Kit for 1200-EC and 2000-EC Lamps (PN 38300)

The standard Dymax EC-Series Lamps employ convection cooling. In situations where supplemental cooling is required or removal of curing vapors from under the Lamp/Reflector Assembly Housing is desired, an optional Ventilation Kit is available. The kit can be a fixed metal skirt that fits on either the rear or the top of the Lamp/Reflector Assembly Housing. The top fan skirt for the 2000-EC and 1200-EC Lamps is provided with the purchase of a Shutter.



Manual Louvered Shutter (PN 35572) & Electric ZIP™ Shutter (PN 37863)

Safety Enhancing Timing Devices

The Dymax ZIP™ Shutter (retractable) and Manual Louvered Shutter allow timed light exposure, reduce heat on work area surfaces, and reduce operator exposure to UV light.



Light Shield (PN 41175)

The Light Shield is a complete enclosure with 360° of shielding. It is constructed so the operator can safely observe objects in the curing process through a window in the front door.

Contact the professionals at Fiber Optic Center for a quote or to get more details.

focenter.com • 508-992-6464 | (800) 473-4237 • sales@focenter.com

23 Centre Street • New Bedford, MA 02740 USA

Specifications

General Specifications

Table 1.
General Specifications



Property	Specification		
	1200-EC	2000-EC	5000-EC
Model			
Reflector Housing Dimensions, W x D x H	10.5" x 9.0" x 7.5" [26.7 cm x 22.9 x cm x 19.1 cm]	10.5" x 9.0" x 7.5" [26.7 cm x 22.9 cm x 19.1 cm]	6.75" x 6.75" x 8.0" [17.2 cm x 17.2 cm x 20.3 cm]
Weight	3.4 lbs. [1.5 kg]		2.7 lbs. [1.2 kg]
Typical Initial Output Intensity at UV-A* (365 nm)	400 mW/cm ²	105 mW/cm ²	225 mW/cm ²
Overall Unit Dimensions, Approx.	16" x 12" x 19" [40.6 cm x 30.5 cm x 48.3 cm] W x D X H		
Power Supply Dimensions, Approx.	16" x 12" x 4.25" [40.6 cm x 30.5 cm x 10.8 cm] W x D X H		
Bulb Life	2,000 hours (warranted)		
Hour Meter	99,999.9 hours (non-resettable)		
Bulbs	38560 400 Watt, metal halide (standard) 36970 400 Watt, mercury vapor (optional) 36658 400 Watt, visible (optional)		

* 1200-EC: Intensity 4.5" from bottom edge of lamp/reflector assembly housing with the beam focused; 5000-EC: Intensity 3" below bottom edge of lamp/reflector assembly housing. All measured with an ACCU-CAL™ 50 UV Radiometer calibrated and traceable to NIST.

Contact the professionals at Fiber Optic Center for a quote or to get more details.

focenter.com • 508-992-6464 | (800) 473-4237 • sales@focenter.com

23 Centre Street • New Bedford, MA 02740 USA

Product data subject to change without notice. FOC last update 2/18/2026.

Figure 11.
EC Flood Lamp Spectral Output –400-Watt Flood Bulbs

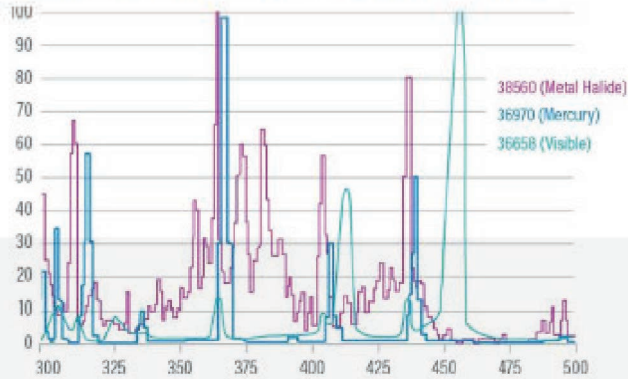

Electrical Specifications

Table 2.
Electrical Specifications

Property	Specification
Power Supply	
Power Outage Range	Factory set to 395 Watts
Operating Temperature	0 to 50°C
Storage Temperature	-20 to 80°C
Operating Humidity	0-80% relative humidity, non-condensing
Flood Lamps	
Main Voltage	90 - 264 VAC
Line Frequency	47-63 Hz
Current Consumption (max)	@115 VAC 8A @230 VAC 4A
Inrush Current (max)	30A
Electrical Regulation	+/- 2.5% for effects of load, line, temperature
Output Protection	Short circuit and overload protected
Auxiliary DC Outputs	+24V, 1A available for lamp housing fan and shutters +/- 24V, ~0.5A and +6V unregulated

Contact the professionals at Fiber Optic Center for a quote or to get more details.

Definition of Terms

Brightness, also known as **Luminance** - Description of energy in the visible region of the spectrum (approximately from 400 to 700 nm) and recorded in photometric units. "**Intensity**" (see below) of visible light energy is called Illuminance.

Dose - irradiance integrated over time, or Irradiance (W/cm²) x Time (s) = Dose (Joules/cm²).

NOTE: Watt is the power that gives rise to the production of energy at the rate of 1-joule (J) per second (s).

Flood Lamp System - set of components arranged to generate, collect, condition, and direct UV radiant energy to perform curing of engineering adhesives, coatings, and inks within a safe and controlled process. It includes a lamp housing and power supply and may also include a shutter, workstation, UV enclosure, Dymax light shield, and/or accessories.

Intensity - a measure of light energy over the unit of surface area (usually the surface at the specified working distance from the bottom of the reflector housing) in W/cm² or mW/cm².

Lamp - light source (bulb or burner) generating ultraviolet, visible, and infrared radiant energy from burning matter stimulated by electrical power conditioned by a proper power supply which is an integral part of a lamp. A light source is usually placed into a reflector (of various geometry) to increase light source efficiency by collecting and directing radiant energy of selected spectra (for a given curing process).

Luminance - Luminous flux (energy of visible light) incident per unit area, and measured in Lx (lux) or Lumen/cm².

Ozone - oxidizing agent (O³) produced by the action of ultraviolet radiant energy (below 185 nm) or electrical corona discharge of oxygen on air.

Ultraviolet (UV) - The invisible region of the spectrum just beyond the violet end of the visible region. Wavelength ranges in general from 1.0 to 400 nm. Dymax lamps (bulbs) do not radiate energy in deep ultraviolet; there are very minute amounts below 220 nm and practically nothing can be sensed below 200 nm. This is due to the use of ozone-blocking quartz bulb envelope (See Ozone).

Ultraviolet is used beneficially in various fields of industry and medicine. In order to standardize light sources used in medicine, the International Congress on Light, in Copenhagen in 1932, recommended dividing the ultraviolet spectrum into three spectral parts:

- **Ultraviolet A (UV-A)** - UV of long wavelength from within approximately 400 to 320 nm of the spectral band (4000 to 3200 \AA) - predominately produced by Dymax flood lamps.
- **Ultraviolet B (UV-B)** - UV of medium wavelength from within approximately 320 to 280 nm - Dymax flood lamps produce some amount of their energy within this bandwidth.
- **Ultraviolet C (UV-C)** - UV of short wavelength below 280 nm (we say from 280 to 200 nm) - a large amount of this energy is present in the sunlight.

OSHA 1910.145: "Regulation of Accident prevention Signs and Tags" defines the following headers as:

- **WARNING** - is used when there is a hazardous situation that has some probability of severe injury.
- **CAUTION** - is used to indicate a hazardous situation that may result in minor or moderate injury.
- **NOTICE** - is used to convey a message related directly or indirectly to the safety of personnel, or protection of property.

Contact the professionals at Fiber Optic Center for a quote or to get more details.

focenter.com • 508-992-6464 | (800) 473-4237 • sales@focenter.com

23 Centre Street • New Bedford, MA 02740 USA

USER GUIDE

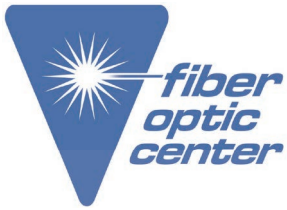

Manufacturer:

Dymax

Product Name:

Dymax 2000-EC UV Curing Flood Lamp

Manufacturer Part Number:

38105

▶ [Click here for more details on the Dymax 2000-EC UV Curing Flood Lamp](#)

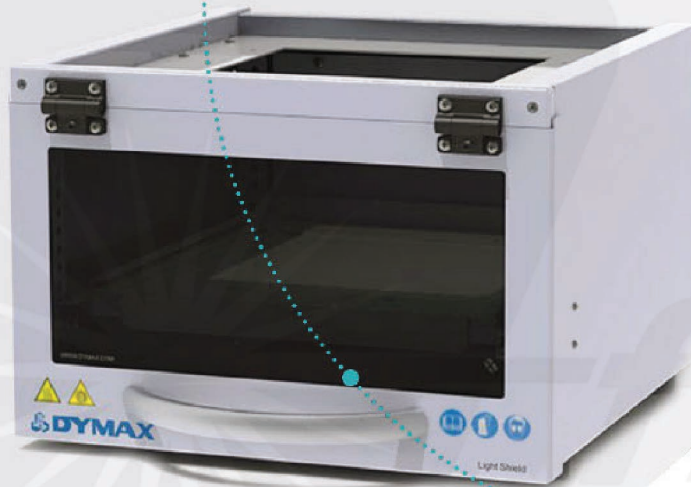

*fiber
optic
center*

UV Light Shield

For use with EC Flood Systems

User Guide



>> [Return to Page 1](#)

Contact the professionals at Fiber Optic Center for a quote or to get more details.

focenter.com • 508-992-6464 | (800) 473-4237 • sales@focenter.com

23 Centre Street • New Bedford, MA 02740 USA

Product data subject to change without notice. FOC last update 2/18/2026.

Contents

Introduction	4
Safety	4
General Safety Considerations.....	4
Specific Safety Considerations.....	4
Safety Symbol Index.....	5
Product Overview	5
Description of the UV Light Shield.....	5
System Components.....	5
Special Features and Benefits.....	6
Assembly and Setup	7
Unpacking and Inspecting Your Shipment.....	7
Parts Included in the Light Shield.....	7
System Interconnection.....	8
Optional: Assembling the Safety Interlock Switch.....	14
Operation	15
Cleaning and Maintenance	15
General.....	15
Spare Parts and Accessories	16
Specifications	17
Definition of Terms	18

[>> Return to Page 1](#)

Contact the professionals at Fiber Optic Center for a quote or to get more details.

focenter.com • 508-992-6464 | (800) 473-4237 • sales@focenter.com

23 Centre Street • New Bedford, MA 02740 USA

Product data subject to change without notice. FOC last update 2/18/2026.

Introduction

This guide describes how to assemble, use, and maintain the Dymax UV Light Shield safely and efficiently.

Intended Audience

Dymax prepared this user guide for experienced process engineers, technicians, and manufacturing personnel.

Safety



WARNING! If you use this UV light shield without first reading and understanding the information in this user guide, injury can result from exposure to high-intensity light. To reduce the risk of injury, read and ensure you understand the information in this user guide before assembling and operating a Dymax flood lamp system with light shield.

General Safety Considerations

All users of Dymax equipment should read and understand this user guide before assembling and using the equipment.

To learn about the safe handling and use of light-curable formulations, obtain and read the SDS for each product.

Specific Safety Considerations

The light shield is designed to maximize operator safety and minimize exposure to light-curing energy. To use the shield safely, it must be set up and operated in accordance with the instructions in this user guide. Please also read and understand the safety considerations unique to flood lamp light-curing systems.

[>> Return to Page 1](#)

Contact the professionals at Fiber Optic Center for a quote or to get more details.

focenter.com • 508-992-6464 | (800) 473-4237 • sales@focenter.com

23 Centre Street • New Bedford, MA 02740 USA

Product data subject to change without notice. FOC last update 2/18/2026.

Safety Symbol Index

The following symbols are displayed on the Dymax light shield. Please see below for their meanings.



Refer to Manual



Gloves Required



Eye Protection Required



Warning!



Caution! Hot Surface



Warning! UV Light Hazard

Product Overview

The Dymax light shield is part of a UV flood-lamp light-curing system that incorporates an optional shutter and a light source into a unique system. These systems generate conditioned quality UV light for curing photosensitive adhesives, coatings, and inks applied to various size and shape parts. This light shield can accommodate all Dymax EC silver series flood lamps and can be used with the Dymax ZIP™ Shutter or manual shutter to optimize an application, providing higher throughput at the best curing quality.

The flood-lamp curing system can also be used without the shutter in rare cases when especially long (several hours) exposure is needed, or timing accuracy is not an issue. If no shutter is used, a bypass connector must be installed on the reflector.

The light shield serves as the base of a flood-lamp system. It is constructed so the operator can safely observe objects in the curing process. The light shield features a front loading door which swings up and down on dual supporting hinges. The door has an optional interlock switch (PN 41166) that can be installed with a ZIP™ shutter to prevent the shutter from being open when the light shield door is open. The light shield also includes a fireproof tray, which slides along adjustable height rails and can be removed and replaced with ease.

Contact the professionals at Fiber Optic Center for a quote or to get more details.

focenter.com • 508-992-6464 | (800) 473-4237 • sales@focenter.com

23 Centre Street • New Bedford, MA 02740 USA

Figure 1.
Main Components of the EC Light Shield

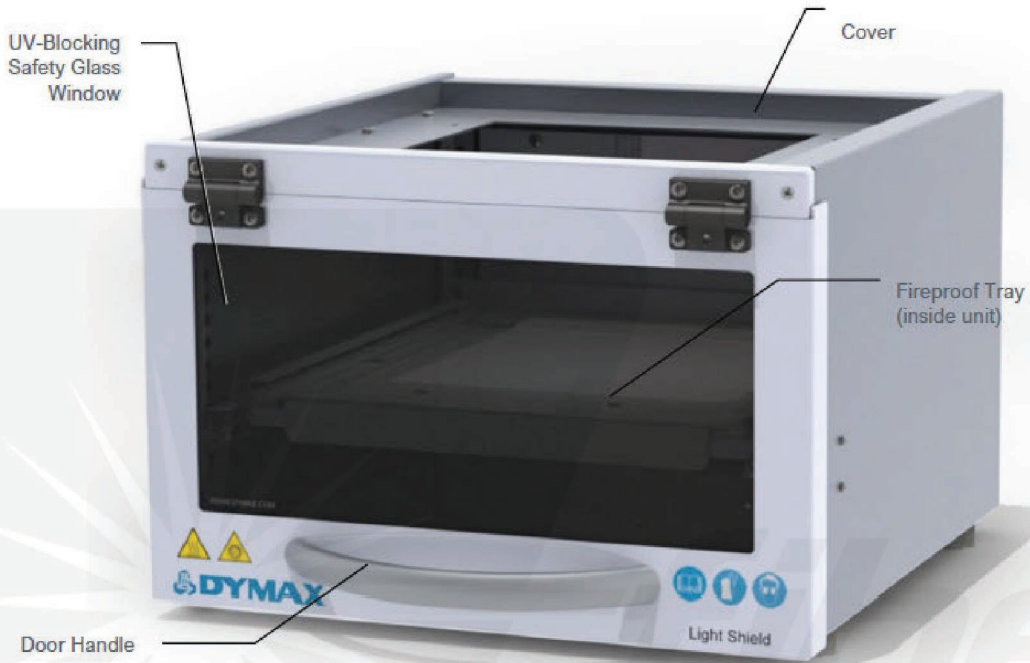

Special Features and Benefits

Key features include:

Feature	Benefit
Accommodates parts for curing up to 7.5" [19.05 cm] high	Can be used with a variety of part configurations
Work surface may be adjusted from 2"- 6.5" [3.81 cm – 13.47 cm] from the bottom of the enclosure	The light shield tray can be used with light-curing applications for a variety of size products
Optional door interlock	Extra safety precaution preventing the shutter from being open when the light shield door is open

>> Return to Page 1

Contact the professionals at Fiber Optic Center for a quote or to get more details.

focenter.com • 508-992-6464 | (800) 473-4237 • sales@focenter.com

23 Centre Street • New Bedford, MA 02740 USA

Product data subject to change without notice. FOC last update 2/18/2026.

Assembly and Setup

Unpacking and Inspecting Your Shipment

When your UV Light Shield arrives, inspect the boxes for damage and notify the shipper of box damage immediately.

Open each box and check for equipment damage.

Check that the parts included in your order match those listed below.

Parts Included in the Light Shield

- Light Shield with Tray (1)
- Light Shield User Guide (2)
- 2000-EC/1200-EC Reflector Support Plate (3)
- 5000-EC Reflector Support Plate (4)
- Screws: 8-32 x 1/2" (5) and 6-32 x 1/2" (6) Socket-Head Screws
- 3/32 (7) & 5/64 (8) Hex Wrenches
- Cable - Reflector to Light Shield (9)

Figure 2.
Light Shield (PN 41175) Components

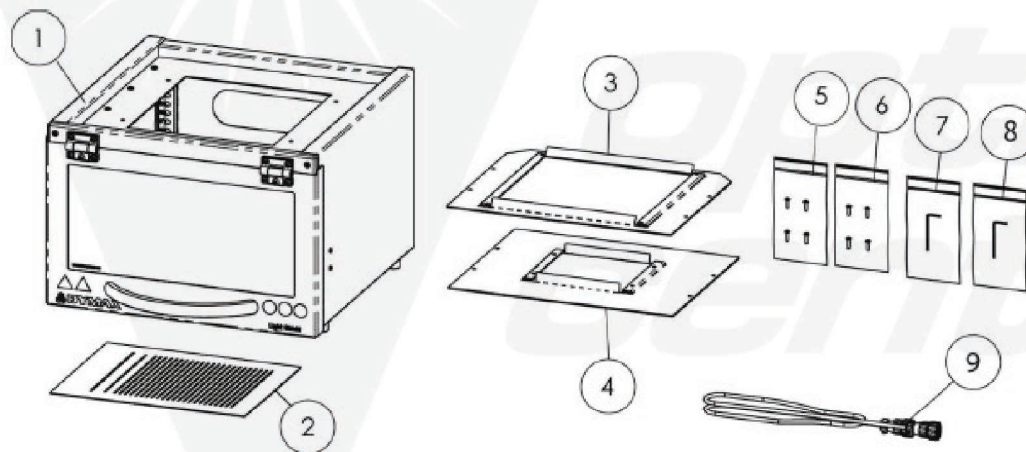

Contact the professionals at Fiber Optic Center for a quote or to get more details.

System Interconnection

Place the Light Shield on the designated workbench. Remove all packaging used for securing the unit during shipping and save it in the event you need to repackage the unit for return.

Suggested Sequence of Flood-Lamp Curing System Connection

1. Install the Bulb (included with Flood Lamp) into the Reflector Housing Assembly; follow the installation instructions provided with the Bulb.
2. Connect one end of the Interconnection Cable to the J2 Connector on the rear panel of the Power Supply and the other end to the 8-Pin Receptacle (J3) on the rear of the Reflector Housing Assembly.
3. Connect the Foot Pedal to the 4-Pin Receptacle (J2) located on the right rear of the Shutter (optional).
4. Connect the Cable provided with the Shutter from the 8-Pin Connector (J4) on the rear of the Reflector Housing Assembly to the 8-Pin Connector (J1) on the rear of the ZIP™ Shutter.

NOTE: If no Shutter is being used, install the Bypass Connector in the 4-Pin Receptacle (J4) instead.

5. Connect the Cable provided with the Light Shield from the J5 9-Pin Connector on the rear of Reflector Housing Assembly to the 9-Pin Connector located on back of Light Shield.
6. Plug the female connector of an AC Power Cord into the J1 - Male Receptacle on the rear panel of the Power Supply.

Figure 3.
Suggested Flood-Lamp Curing System Interconnect

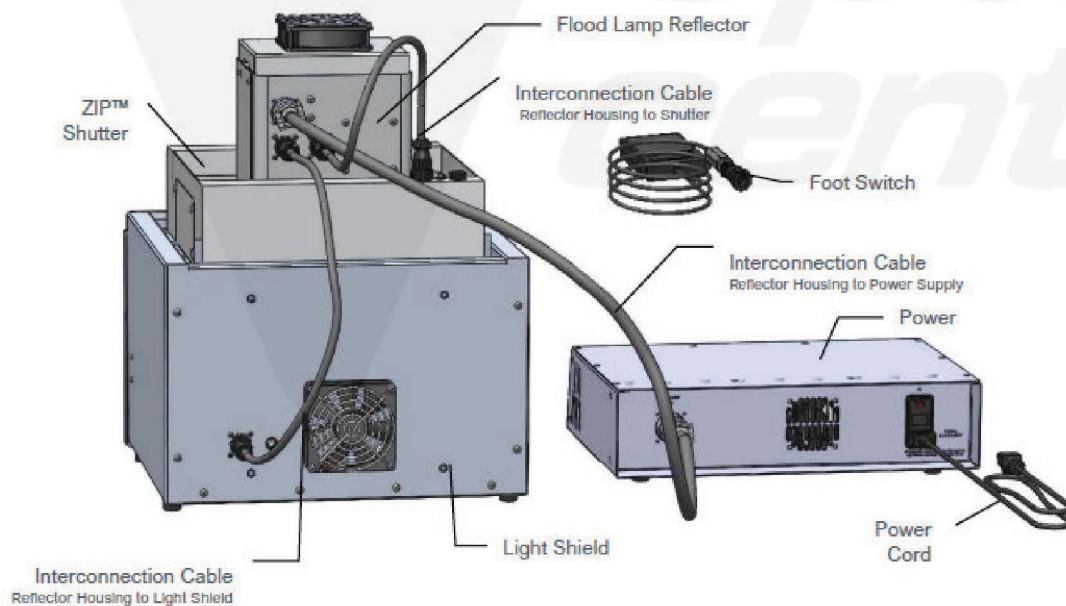

>> Return to Page 1

Contact the professionals at Fiber Optic Center for a quote or to get more details.

focenter.com • 508-992-6464 | (800) 473-4237 • sales@focenter.com

23 Centre Street • New Bedford, MA 02740 USA

Product data subject to change without notice. FOC last update 2/18/2026.

WARNING! Do not position the Light Shield on top of the Power Supply. The EC Flood Lamp System requires adequate air circulation. Setting up the system in such a configuration can result in damage to the equipment and unsafe operating conditions.

Figure 4.
Unacceptable Mounting Configuration



Installing the Reflector Housing Directly to the Light Shield

1. Invert the Reflector and remove the four Screws (Figure 5).

Figure 5.
Remove Four Screws on the Reflector

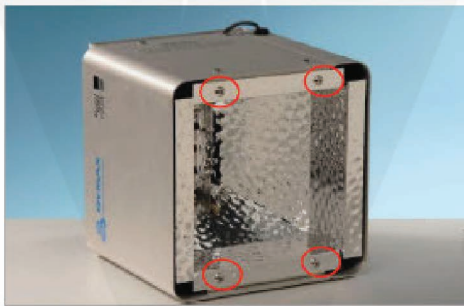

5000-EC (8-32 x 1/4" Screws)



2000-EC (6-32 x 1/2" Screws)

2. If using the 2000-EC Reflector, an optional glass filter is available. To install the Glass Filter Plate, remove the two Support Bars and four Spacers from the 2000-EC Reflector. Place the Glass Filter Plate on the Reflector and position the four Spacers around the Glass Filter Plate. Reinstall the two Support Bars.
3. Fasten the appropriate Support Plate to the Reflector with the four screws removed in Step 1 (Figure 6).

NOTE When using a 2000-EC lamp, position the Support Plate so that the end with cropped corners is facing the rear of the Reflector. The Reflector/Support Plate Assembly will not sit flush on the Light Shield if this plate is attached backwards.

Contact the professionals at Fiber Optic Center for a quote or to get more details.

Figure 6.
Fasten the Appropriate Support Plate to the Reflector

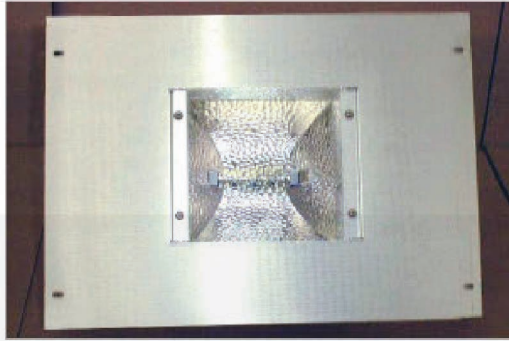

5000-EC (8-32 x ¼" Screws)



2000-EC (6-32 x ½" Screws)

4. Remove the four M4 x 8-mm screws from the Light Shield's Top Cover (Figure 7).
5. Place the Reflector/Support Plate Assembly onto the Light Shield. Align the holes on the Light Shield Top Plate and the Support Plate and then secure the Reflector/Support Plate Assembly to the Light Shield with the M4 x 8-mm screws.

NOTE: Do not tighten until directed in Step 5.

Figure 7.
Remove Screws from Light Shield Top Cover



Figure 8.
Secure the Reflector/Support Plate Assembly to the Light Shield

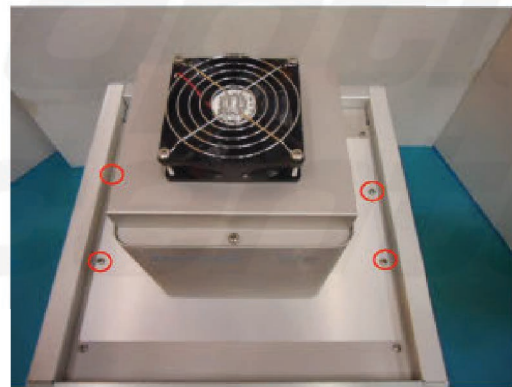

6. Center the Reflector Housing on the Light Shield. When the desired position is achieved, tighten the Securing Brackets to the Light Shield (Figure 8).
7. Install cable PN 40878 between the connector on the rear of the Light Shield and J5 on the back of the reflector (this cable is packaged with the Light Shield). Install the larger Cable (PN 37904) between J3 on the back of the Reflector and the back of the Power Supply. Install the Power Cable (PN 35255) to the back of the Power Supply.

>> Return to Page 1

Contact the professionals at Fiber Optic Center for a quote or to get more details.

focenter.com • 508-992-6464 | (800) 473-4237 • sales@focenter.com

23 Centre Street • New Bedford, MA 02740 USA

Product data subject to change without notice. FOC last update 2/18/2026.

Figure 9.
Rear Connections (5000-EC Shown)

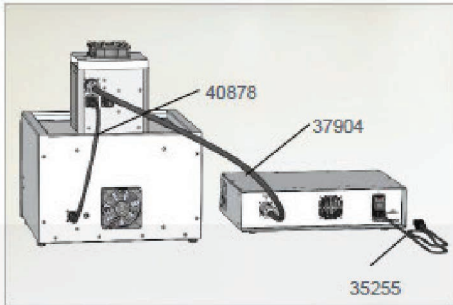

Figure 10.
Complete Installed System (2000-EC Shown)



Installing the Light Shield to a Reflector Housing with a Shutter

1. Take a Shutter and carefully place it on the top of the Light Shield.
2. The Shutter is shipped with the 5000-EC Support Plate installed. Remove the four screws to remove the 5000-EC Support Plate from the Shutter (Figure 11).

NOTE: If you are using a 2000-EC lamp, this plate will not be used. If you are using a 5000-EC lamp, the Support Plate will be installed on the Reflector at a later time.

Figure 11.
Remove 5000-EC Support Plate from Shutter

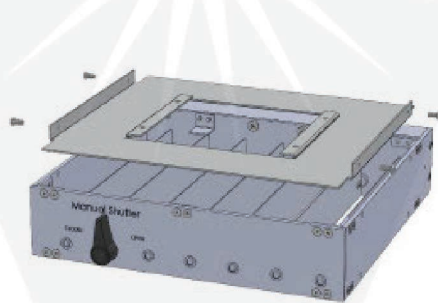

Manual Shutter

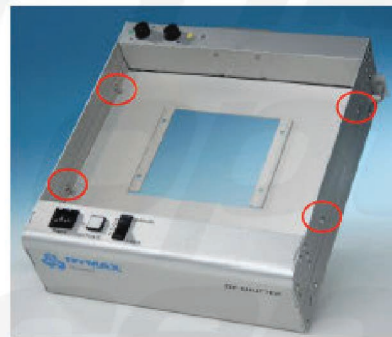

ZIP™ Shutter

3. Invert the Reflector and remove the four Screws (Figure 5).

Contact the professionals at Fiber Optic Center for a quote or to get more details.

focenter.com • 508-992-6464 | (800) 473-4237 • sales@focenter.com

23 Centre Street • New Bedford, MA 02740 USA

Figure 12.
Remove Four Screws on the Reflector

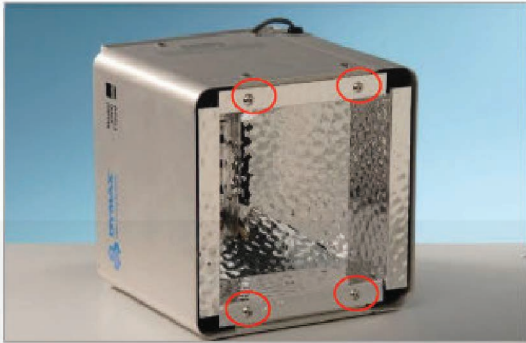

5000-EC (8-32 x 1/4" Screws)

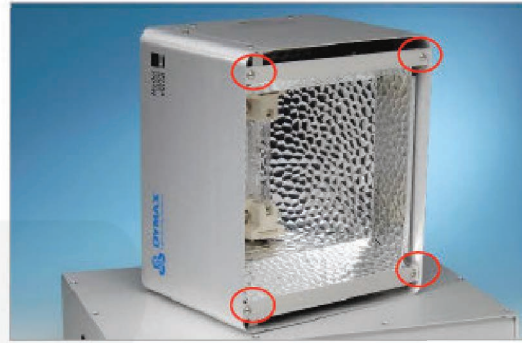

2000-EC (6-32 x 1/2" Screws)

4. Install the Support Brackets to the top of Light Shield with the 8-32 x 3/8" screws provided.

NOTE: Do not tighten until directed to in Step 5.

5. Prepare the Reflector Housing with the appropriate Support Plate(s) for use with the Shutters (Figure 13). Refer to the Shutter User Guide for more details.

NOTE: Do not install the Reflector Housing to the Shutter by installing the four 8-32 x 3/8" screws and fastening the Support Plate(s) to the Reflector Housing until directed.

Figure 13.
Install Appropriate Support Plate

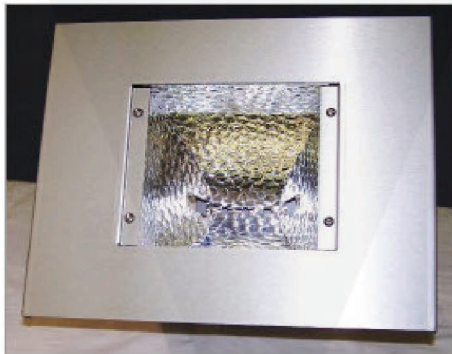

5000-EC

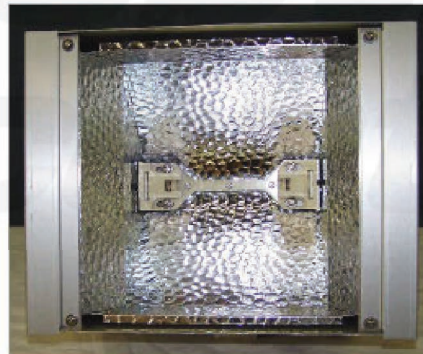

2000-EC

6. Place the Reflector Housing/Support Plate(s) Assembly into the Shutter. Using the 8-32 x 3/8" screws provided with the Shutter, secure the Light Shield and Shutter to the Reflector Housing Support Plate(s). (Figure 14)

>> Return to Page 1

Contact the professionals at Fiber Optic Center for a quote or to get more details.

focenter.com • 508-992-6464 | (800) 473-4237 • sales@focenter.com

23 Centre Street • New Bedford, MA 02740 USA

Product data subject to change without notice. FOC last update 2/18/2026.

Figure 14.
Securing Bracket



ZIP™ Shutter



Manual Shutter

7. Center the Shutter on the Light Shield. When the desired position is achieved, tighten the Securing Brackets to the Light Shield.
8. If using a ZIP™ Shutter, install Cable PN 40879 between the Shutter and the back of the Reflector. There is no Interconnect Cable between the Manual Shutter and the Reflector.
9. Install cable PN 40878 between the connector on the rear of the Light Shield and the back of the Reflector (these two Cables are packaged with the Shutter). These cables are color coded to aid assembly.

Install the large Cable between the back of the Reflector and the back of the Power Supply. Install the Power Cable to the back of the Power Supply.

Figure 15.
Completely Assembled System (ZIP™ Shutter Shown)



5000-EC



2000-EC

Contact the professionals at Fiber Optic Center for a quote or to get more details.

focenter.com • 508-992-6464 | (800) 473-4237 • sales@focenter.com

23 Centre Street • New Bedford, MA 02740 USA

Optional: Assembling the Safety Interlock Switch

Figure 16.
Light Shield (Shown Upside Down)

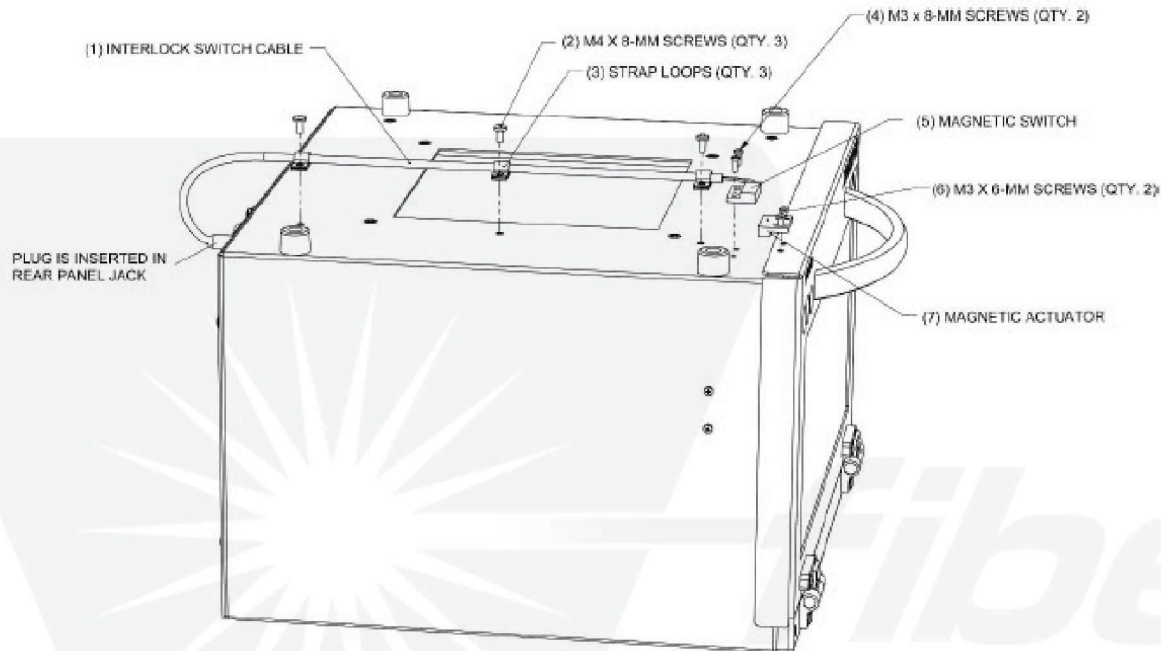

1. Turn off the power and remove all cables from the Light Shield.
2. Remove the Reflector Housing and Shutter from the top of the Light Shield. Turn the Light Shield upside down (Figure 16).
3. Remove the five screws from the bottom of the unit.
4. Attach the Magnetic Switch (5) to the bottom of the housing using two M3 x 8-mm Screws (4).
5. Fasten the Interlock Switch Cable to the bottom of the unit using the Nylon Strap Loops (3) and M4 x 8-mm Screws (2).
6. Remove the three 10-32 screws (5) from the left side of the Light Shield. Route the Interlock Switch Cable along the left side of the Light Shield and fasten the cable into place by using the three Cable Clamps (4) and longer screws provided in this kit.
7. Attach the Magnetic Actuator (7) to the Light Shield Door using the M3 x 6-mm Screws (6).
Note: Check that the Magnetic Switch and the Magnetic Actuator are aligned.
8. Plug the Connector to the Power Jack at the back of the Light Shield.
9. Turn the Light Shield right side up and reinstall the Shutter and Reflector to the Light Shield.

>> Return to Page 1

Contact the professionals at Fiber Optic Center for a quote or to get more details.

focenter.com • 508-992-6464 | (800) 473-4237 • sales@focenter.com

23 Centre Street • New Bedford, MA 02740 USA

Product data subject to change without notice. FOC last update 2/18/2026.

Operation

For a detailed description of flood lamp operation, maintenance, and troubleshooting, see the appropriate flood lamp operation manual. This is a suggested sequence of activities that can be altered to better match your working conditions, process requirements, and work habits.

Estimate the height of the curing part in respect to its base, or to the base of the part holder (if the object to be cured is not free standing), and then adjust the position of the work surface at a proper distance from the curing part. Use a ruler for setting accuracy.

The recommended working distances for each type of reflector housing assembly is indicated in the appropriate flood lamp manual. You can set this distance differently to optimize your throughput with respect to adhesive properties and irradiant energy required to achieve the best curing quality in the shortest time.

Cleaning and Maintenance

General

UV Light Shield

The UV light shield is designed to be maintenance free. Periodic cleaning will ensure long, trouble-free operation.

Flood Lamps

See the appropriate flood lamp manual for maintenance recommendations.

Shutters

See the appropriate shutter manual for maintenance recommendations.

*fiber
optic
center*

Contact the professionals at Fiber Optic Center for a quote or to get more details.

focenter.com • 508-992-6464 | (800) 473-4237 • sales@focenter.com

23 Centre Street • New Bedford, MA 02740 USA

Spare Parts and Accessories

Item	Part Number
Cables	
Reflector Housing to Light Shield Cable	40878
Interlock Switches	
Interlock Switch	41166
Interlock Switch – For Light Shield PN 38125	38402
Misc. Replacement Parts	
Front Door Handle	40808
Hinge, Friction, Adjustable	36447
Fan Assembly, 24 Volts	40823
Work Surface Tray Assembly	40806
Shields	
Door Assembly Shield	41157
Housing Light Shield	40793
Plate Top Shield	40802

*Fiber
optic
center*

>> [Return to Page 1](#)

Contact the professionals at Fiber Optic Center for a quote or to get more details.

focenter.com • 508-992-6464 | (800) 473-4237 • sales@focenter.com

23 Centre Street • New Bedford, MA 02740 USA

Product data subject to change without notice. FOC last update 2/18/2026.

Specifications

Property	Specification
Part Number	41175
Compatible Dymax Flood Lamps	5000-EC, 2000-EC, & 1200-EC
Compatible Shutters	37863 ZIP™ Shutter 35572 Manual Shutter
Compatible Dymax Bulbs	Standard – 400 Watt Metal Halide Bulb Optional – 400 Watt Hg Vapor Bulb Optional – 400 Watt Visible Bulb
Work Area	10" x 10" [25.4 cm x 25.4 cm]
Work Surface Load Capacity	Up to 5 lbs. [2.27 kg]
Overall Dimensions (W x D x H)	18.2" x 15.1" x 10.6" [46.25 cm x 38.42 cm x 26.83 cm]
Interface Cable Length (standard)	24" [60.96 cm]
Weight (Light Shield Only)	14.5 lbs [6.58 kg]
Unit Warranty	1 year from purchase date

Figure 17.
EC Light Shield Dimensions

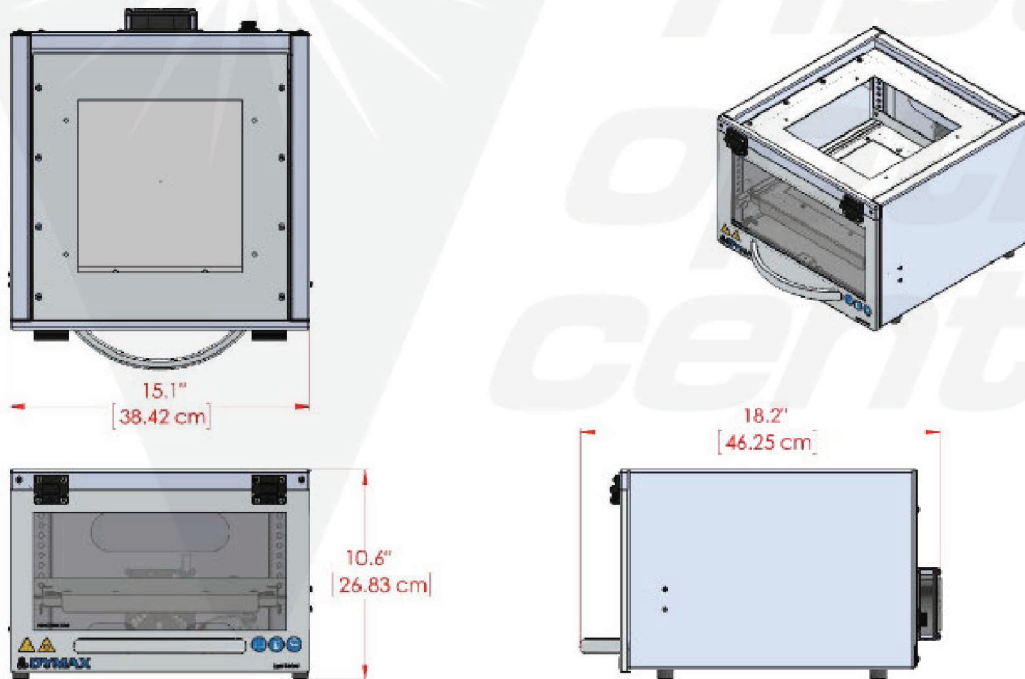

Contact the professionals at Fiber Optic Center for a quote or to get more details.

Definition of Terms

Brightness, also known as **Luminance** - description of energy in the visible region of the spectrum (approximately from 400 to 700 nm) and recorded in photometric units. "**Intensity**" (see below) of visible light energy is called Luminance.

Bulb - light source generating ultraviolet, visible, and infrared radiant energy from burning matter stimulated by electrical power conditioned by a proper power supply which is an integral part of a lamp. A light source is usually placed into a reflector (of various geometry) to increase light source efficiency by collecting and directing radiant energy of selected spectra (for a given curing process).

Dose - is irradiance integrated over time, or Irradiance (W/cm^2) x Time (s) = Dose ($Joules/cm^2$). Note: Watt is the power that gives rise to the production of energy at the rate of 1-joule (J) per second(s).

Intensity - a measure of light energy over the unit of surface area (usually surface at the specified working distance from the bottom of a reflector housing) in W/cm^2 or mW/cm^2 . For the UV portion of light, this measure is often called in literature "irradiance", i.e. radiant energy arriving at a point on a surface per unit area.

Luminance - luminous flux (energy of visible light) incident per unit area, and measured in Lx (lux) or Lumen/cm².

Ozone - oxidizing agent (O₃) produced by the action of Ultraviolet radiant energy (below 185 nm) or electrical corona discharge of oxygen on air.

Ultraviolet (UV) - The invisible region of the spectrum just beyond the violet end of the visible region. Wavelength ranges in general from 1.0 to 400 nm. Dymax bulbs (burners) do not radiate energy in deep Ultraviolet; there are very minute amounts below 220 nm and practically nothing can be sensed below 200 nm. This is due to the use of an ozone-blocking quartz bulb envelope (See Ozone).

1. **Ultraviolet A (UV-A)** - UV of long wavelength from within approximately 400 to 320 nm of the spectral band (4000 to 3200 \AA) - predominately produced by Dymax Flood Lamps.
2. **Ultraviolet B (UV-B)** - UV of medium wavelength from within approximately 320 to 280 nm - Dymax Flood Lamps produce some amount of their energy within this bandwidth.
3. **Ultraviolet C (UV-C)** - UV of short wavelength below 280 nm (we say from 280 to 200 nm) - a large amount of this energy is present in sunlight.
4. **Visible** - Light that can be seen 400-700 nm.

OSHA 1910.145: "Regulation of Accident prevention Signs and Tags" defines the following headers as:

- **WARNING** - is used when there is a hazardous situation that has some probability of severe injury.
- **CAUTION** - is used to indicate a hazardous situation that may result in minor or moderate injury.
- **NOTICE** - is used to convey a message related directly or indirectly to the safety of personnel or protection of property.

[>> Return to Page 1](#)

Contact the professionals at Fiber Optic Center for a quote or to get more details.

focenter.com • 508-992-6464 | (800) 473-4237 • sales@focenter.com

23 Centre Street • New Bedford, MA 02740 USA

Product data subject to change without notice. FOC last update 2/18/2026.