

USER GUIDE

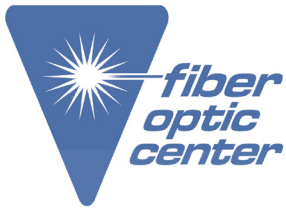

Manufacturer:
Dymax

Product Name:
Dymax UV Protective Safety Goggles - Gray Lens

Manufacturer Part Number:
35285

▶ [Click here for more details on the Dymax UV Protective Safety Goggles - Gray Lens](#)

Click the thumbnail below to navigate to the User Guide



[Silver EC Series
UV Light Curing Flood Lamps](#)



[Bluemax® MX-150
LED Spot-Curing Emitters](#)

Contact the professionals at Fiber Optic Center for a quote or to get more details.

focenter.com • 508-992-6464 | (800) 473-4237 • sales@focenter.com

23 Centre Street • New Bedford, MA 02740 USA

Product data subject to change without notice. FOC last update 6/19/26

USER GUIDE

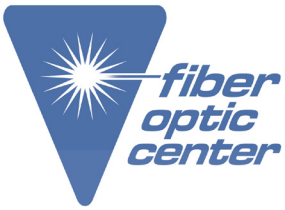

Manufacturer:

Dymax

Product Name:

Dymax UV Protective Safety Goggles - Gray Lens

Manufacturer Part Number:

35285

▶ [Click here for more details on the Dymax UV Protective Safety Goggles - Gray Lens](#)

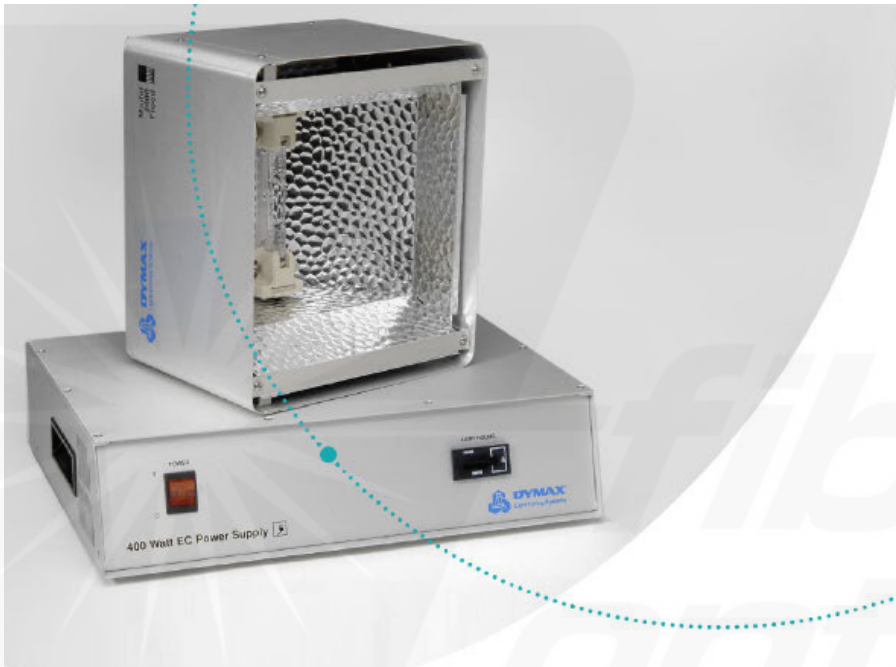

Silver EC-Series UV Light-Curing Flood Lamps User Guide



[>> Return to Page 1](#)

Contact the professionals at Fiber Optic Center for a quote or to get more details.

focenter.com • 508-992-6464 | (800) 473-4237 • sales@focenter.com

23 Centre Street • New Bedford, MA 02740 USA

Product data subject to change without notice. FOC last update 6/19/26

Contents

Introduction	4
Safety	4
General Safety Considerations.....	4
Specific Safety Considerations.....	5
Dymax UV Light-Curing System Safety Considerations	5
Product Overview	7
Description of the EC Series Flood Lamps	7
System Components.....	7
Assembly and Setup	9
Unpacking and Inspecting Your Shipment.....	9
Parts Included in an EC Flood Lamp	9
System Interconnection	10
Operation	11
Cleaning and Maintenance	12
Bulb Replacement Procedure.....	12
Lamp Base Replacement Instructions	13
Fuse Replacement Procedure	14
Cleaning.....	15
Preventing Unit Overheating.....	15
Troubleshooting	17
Spare Parts and Accessories	18
Accessories.....	19
Specifications	20
General Specifications.....	20
Electrical Specifications.....	21
Definition of Terms	22

>> Return to Page 1

Contact the professionals at Fiber Optic Center for a quote or to get more details.

focenter.com • 508-992-6464 | (800) 473-4237 • sales@focenter.com

23 Centre Street • New Bedford, MA 02740 USA

Product data subject to change without notice. FOC last update 6/19/26

Introduction

This guide describes how to assemble, use, and maintain a Dymax EC-series flood lamp system safely and efficiently.

Intended Audience

Dymax prepared this user guide for experienced process engineers, technicians, and manufacturing personnel.

Safety



WARNING! If you use a Dymax UV flood lamp system without first reading and understanding the information in this user guide, injury can result from exposure to UV light. To reduce the risk of injury, read and ensure you understand the information in this user guide before assembling and operating an EC-series flood lamp.

General Safety Considerations

All users of Dymax light-curing flood lamps should read and understand this user guide before assembling and using the system.

To learn about the safe handling and use of light-curable formulations, obtain and read the MSDS for each product.

Contact the professionals at Fiber Optic Center for a quote or to get more details.

focenter.com • 508-992-6464 | (800) 473-4237 • sales@focenter.com

23 Centre Street • New Bedford, MA 02740 USA

Specific Safety Considerations

Dymax EC-series flood lamps are designed to maximize operator safety and minimize exposure to UV light-curing energy. To use the unit safely, it must be set up and operated in accordance with the instructions in this user guide. Please also read and understand the safety considerations unique to UV light-curing systems as described below.



WARNING! Looking directly at the UV light emitted by an EC flood lamp can result in eye injury. To prevent eye injury, never look directly at the high-intensity light and always wear protective goggles (provided).

Dymax UV Light-Curing System Safety Considerations

Operators must understand these four concepts to use the UV light source safely:

- UV exposure
- High-temperature surfaces
- Ozone
- Bright, visible light

Each is described below.

UV Exposure

Standard Dymax UV light-curing systems and bulbs have been designed primarily to emit UVA light (**Error! Reference source not found.**). UVA light is generally considered the safest of the three UV ranges: UVA, UVB, and UVC. Although OSHA does not currently regulate ultraviolet light exposure in the workplace, the American Conference of Governmental Industrial Hygienists (ACGIH) does recommend Threshold Limit Values (TLVs) for ultraviolet light.

The strictest interpretation of the TLV (over the UVA range) for workers' eyes and skin is 1 mW/cm² (intensity), continuous exposure. Unless workers are placing bare hands into the curing area, it is unusual to exceed these limits. To put 1 mW/cm² limit into perspective, cloudless summer days in Connecticut regularly exceed 3 mW/cm² of UVA light and also include the more dangerous UVB light (primarily responsible for sun tans, sun burns, and skin cancer) as well.

Figure 1.
Spectrum of Light

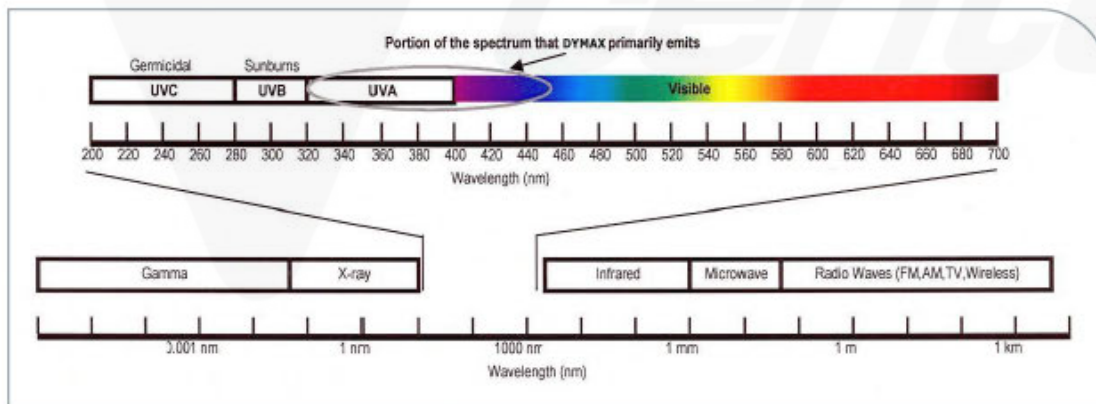

Contact the professionals at Fiber Optic Center for a quote or to get more details.

focenter.com • 508-992-6464 | (800) 473-4237 • sales@focenter.com

23 Centre Street • New Bedford, MA 02740 USA

Checking the Workstation

The human eye cannot detect "pure" UV light, only visible light. A radiometer should be used to measure stray UV light to confirm the safety of a UV light-curing process. A workstation that exposes an operator to more than 1 mW/cm² of UVA continuously should be redesigned.

Protecting Operators

Light-curing technology can be a regulatory compliant, "worker-friendly" manufacturing process when the proper safety equipment and operator training is utilized. There are two ways to protect operators from UV exposure: shield the operator and/or shield the source.

Shield the Operator — UV-Blocking Eye Protection - UV-blocking eye protection is recommended when operating UV light-curing systems.

UV-Blocking Skin Protection — Where the potential exists for UV exposure upon skin, opaque, UV-blocking clothing, gloves, and full-face shields are recommended.

Shield the Source of UV

Any substrate that blocks UV light can be used as a shield to protect workers from stray UV light. The following materials can be used to create simple shielding structures:

Rigid Plastic Film — Transparent or translucent/UV-blocking plastics (typically polycarbonate or acrylic) are commonly used to create shielding where some level of transparency is also desired.

Flexible Film — Translucent UV-blocking, flexible urethane films can be used to quickly create workstation shielding.

Ozone

Standard Dymax bulbs (UVA type) generate an insignificant amount of UVC and therefore essentially no ozone. Some UV light-curing systems, like those used to cure UV inks, emit primarily "shortwave" (UVB and UVC) energy. Upon exposure to UVC light (specifically <240 nm), oxygen molecules (O₂) split into oxygen atoms (O) and recombine with O₂ to create ozone O₃. The current, long-term ozone concentration limit recommended by ACGIH, NIOSH, and OSHA is 0.1 ppm (0.2mg/m³).

High-Temperature Surfaces

Surfaces exposed to high-intensity curing lights will rise in temperature. The intensity, distance, exposure time, cooling fans, and the type/color of the surface can all affect the actual surface temperature. In some cases, exposed surfaces can reach temperatures capable of producing a burn or causing damage to a substrate. In these cases, care must be taken to ensure either a more moderate surface temperature or appropriate protection/training for operators.

Bright, Visible Light

The bright, visible light emitted by some UV light-curing systems can be objectionable to some workers and can cause eyestrain. Tinted eye protection and/or opaque/tinted shielding can be utilized to address this concern.

Summary

UV-light sources can be more "worker friendly" than many commonly accepted industrial processes, provided the potential concerns are addressed. Both the lower working temperature and lack of spurious frequency transmission that this system

Contact the professionals at Fiber Optic Center for a quote or to get more details.

focenter.com • 508-992-6464 | (800) 473-4237 • sales@focenter.com

23 Centre Street • New Bedford, MA 02740 USA

produces make it even more user friendly.

Product Overview

Description of the EC Series Flood Lamps

Dymax EC-Series Flood Lamps are general-purpose curing units used to cure UV light-curable adhesives, coatings, and inks. These light sources are exceptionally versatile and expandable, allowing them to be utilized in an array of manufacturing situations and applications, including bonding, potting, sealing, and encapsulating.

Each unit is designed and shipped in a unitized configuration for easy bench-top mounting. These flood lamps can also be custom configured so the Lamp/Reflector Assembly Housing can be mounted in a remote curing location away from the Power Supply. Several Lamp/Reflector Assembly Housings can be mounted side-by-side in a linear configuration (such as on conveyor systems) or a large area array. The Power Supplies can then be stacked and mounted remotely to provide consolidated operator control. The Lamp/Reflector Assembly Housings are designed with clean, unobstructed surfaces making them easy to install in existing or specialized equipment.

System Components

Flood Lamps

1200-EC

The Dymax 1200-EC is a focused-beam UV Light-Curing Lamp used for the curing of UV light-curable adhesives, coatings, and inks. The unit's elliptical Reflector provides an intense 1" x 6" area of UV energy 4.5" away from the lower edge of the Lamp/Reflector Assembly Housing.

The 1200-EC employs convection cooling. An optional Fan Ventilation Kit is available to remove excessive heat and ventilate curing vapors away from the Lamp/Reflector Assembly Housing. Refer to the spare parts/options section of this manual for more information on the Fan Ventilation Kit.

2000-EC

The Dymax 2000-EC is a general-purpose UV Light-Curing Flood Lamp with an effective curing area of approximately 8" x 8", making it ideal for batch processing or curing large areas.

An optional special Glass UV Filter may be installed in the 2000-EC Reflector to reduce UV-B and UV-C spectral emissions. When operated correctly using the Glass UV Filter, extensive shielding associated with many Lamps can be minimized.

The 2000-EC employs convection cooling. An optional Fan Ventilation Kit is also available. This kit removes excessive heat due to the Lamp's possible proximity to other heat sources, or to remove vapors from under the Lamp/Reflector Assembly Housing during curing of UV light-curable materials. Refer to the spare parts/options section of this manual for more information on the Fan Ventilation Kit.

5000-EC

The Dymax 5000-EC is a general-purpose UV Light-Curing Flood Lamp with an effective curing area of approximately 5" x 5". It is ideal for small batch processing of UV adhesives and potting compounds.

Comparatively, it provides more than twice the output intensity of a 2000-EC Flood Lamp for faster curing capability and the additional ability to cure conformal coating resins.

Contact the professionals at Fiber Optic Center for a quote or to get more details.

focenter.com • 508-992-6464 | (800) 473-4237 • sales@focenter.com

23 Centre Street • New Bedford, MA 02740 USA

Figure 2.
Lamp/Reflector Housings (Left to Right: 1200-EC, 5000-EC, & 2000-EC)



Solid-State Power Supply

The Solid-State Power Supply allows external electrical inputs and provides power to the Lamp. The front panel contains the On/Off Power Switch and Hour Meter. The Power Supply also houses its own Cooling Fan and power distribution for optional accessories. The rear panel has an integrally fused AC-Power Receptacle and an 8-pin female Amp Connector.

The Power Supply yields reliable and stabilized Lamp voltage in virtually any electrical system in the world. Other than ensuring a properly configured plug is employed, no other adjustment of settings is required. The Power Supply also conditions the electrical power to the Lamp providing longer, more reliable Lamp life.

Figure 3.
EC-Series Power Supply



Contact the professionals at Fiber Optic Center for a quote or to get more details.

focenter.com • 508-992-6464 | (800) 473-4237 • sales@focenter.com

23 Centre Street • New Bedford, MA 02740 USA

Product data subject to change without notice. FOC last update 6/19/26

Assembly and Setup

Unpacking and Inspecting Your Shipment

When your flood lamp arrives, inspect the boxes for damage and notify the shipper of box damage immediately.

Open each box and check for equipment damage. If parts are damaged, notify the shipper and submit a claim for the damaged parts.

Check that the parts included in your order match those listed below.

Parts Included in an EC Flood Lamp

- **Reflector Assembly Housing (1)** – Contains lamp sockets, a high-voltage starter, three circular connectors, and one reflector (1200, 2000, or 5000) with an UV lamp (400-Watt, metal halide. Optional visible or mercury vapor bulbs available).
- **UV Glass Filter for the 2000-EC (2)** – Optional
- **Solid-State Power Supply (3)**
- **Interconnection Cable (5)** – Connects the power supply to the lamp/reflector assembly housing.
- **Power Cord (4)** – North American power cord shown
- **UV Protection Goggles (6)**
- **Hex Wrench (7)**
- **Dymax EC-Series UV Flood Lamps User Guide (8)**

Figure 4.
EC Series Flood Lamp Unpacking Diagram

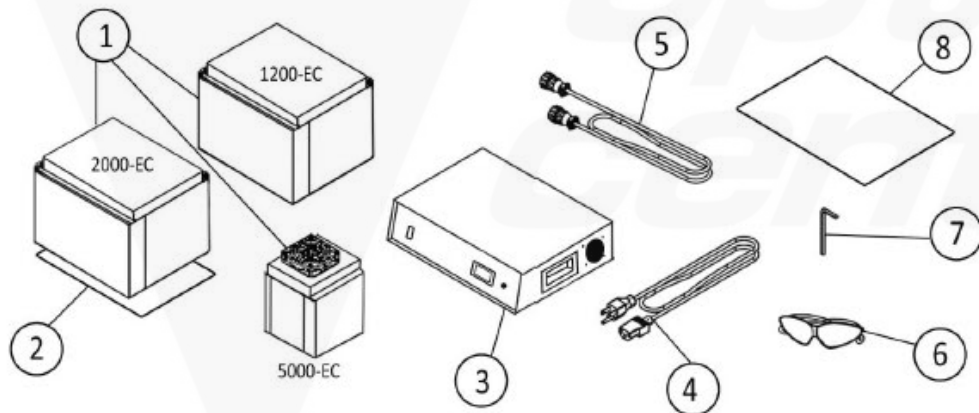

Contact the professionals at Fiber Optic Center for a quote or to get more details.

System Interconnection

Figure 5.
Interconnection Diagram

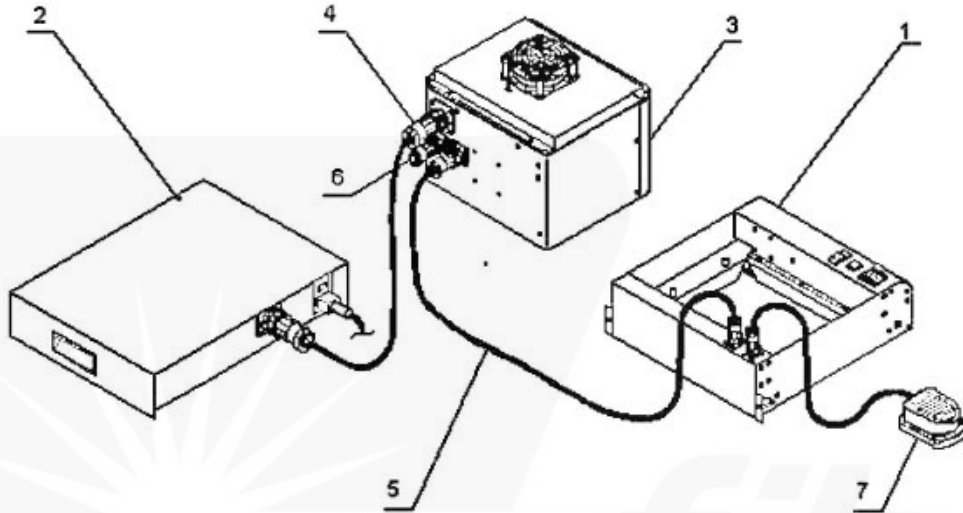

#	Part Description	#	Part Description
1	Shutter, Optional	5	Shutter Interconnect Cable, Optional
2	Power Supply (8-Pin Connector)	6	Plug, Adapter, Optional
3	Reflector (8-Pin Connector)	7	Foot Pedal, Optional
4	8-Pin to 8-Pin Interconnect Cable		

1. Place the 400 Watt Bulb into the Lamp/Reflector Assembly Housing. Refer to the Bulb Replacement/ Installation section of this manual.
2. A Glass UV Filter is available as an option. This Glass UV Filter reduces heat produced by Lamp but will also reduce UV output of Reflector. To install the optional Glass UV Filter (sold only for the 2000-EC Flood Lamp):

NOTICE: It is important to wear protective gloves when installing the Glass UV Filter! Do not touch the Filter with bare fingers! Fingerprints may etch into glass and cause light transmission loss!

- Place the Reflector Housing upside down on a flat surface.
 - Loosen the four screws in the bracket that hold the Reflector to the Housing.
 - Slide the Glass UV Filter under the brackets and adjust it symmetrically over the Reflector Aperture.
 - Tighten the four screws.
3. Locate the Power Supply and Reflector Housing so that there is free air circulation around sides. The Reflector may be mounted to a Dymax Flood Lamp accessory such as a Mounting Stand, Light Shield, or Shutter. See the connecting instructions in the operation manual for the appropriate Dymax accessory.

Contact the professionals at Fiber Optic Center for a quote or to get more details.

focenter.com • 508-992-6464 | (800) 473-4237 • sales@focenter.com

23 Centre Street • New Bedford, MA 02740 USA

WARNING! Always observe safety requirements when working with electrical equipment! Electrical hazard is present!

4. Secure the Reflector Housing in the designated operation location.
5. Connect the Interconnect Cable to the J3 Receptacle on the Reflector Housing (coded red, Figure 6).

NOTE: Cables and receptacles are coded with color dots to assist in the installation of cables. Connections may vary if using a Dymax Flood Lamp accessory such as a Mounting Stand, Light Shield, or Shutter. See the connecting instruction in the operation manual for the appropriate Dymax accessory.

6. Connect the opposite end of the Interconnect Cable to the Lamp Power Receptacle on rear panel of the Power Supply (coded red).
7. Make sure that the other Dymax accessories, if any, are also properly connected and operational.
8. Plug the Power Cord into the Power Module located in the rear panel of the Power Supply (Figure 7) and plug the other end of the Power Cord into an external AC source.

Figure 6.
J3 Receptacle



Figure 7.
Power Module



Operation

Turn the unit on by pressing on the Power Switch (located to the left on front of the Power Supply panel). The switch will light up to indicate that the power is on.

NOTE: While most Lamps typically require less than 30 seconds to ignite, a new Lamp will sometimes require several minutes.

After the Lamp has ignited, allow five minutes for the Lamp to reach its maximum output intensity.

Lamp life is reduced approximately one hour each time it is started. To avoid premature Lamp deterioration, leave the unit on through breaks, short shutdowns, and lunch hours.

These UV Flood Lamps are designed for continuous operation.

Contact the professionals at Fiber Optic Center for a quote or to get more details.

NOTE: If the power is momentarily lost or the Lamp is inadvertently shut off, it must cool down before restarting. This may take 5-10 minutes depending on ambient conditions. The Power Supply may be left energized while the Lamp is cooling. The Lamp will re-light when it has cooled sufficiently.

Each time the Lamp is turned on, it should operate for at least five minutes to allow complete ionization of elements inside the Lamp. Failure to do this may result in failure of the Lamp to restart. Refer to the troubleshooting section of this manual for more information.

Cleaning and Maintenance

Bulb Replacement Procedure

1. Every new EC-Series Flood Lamp is supplied with a new 400-Watt Bulb. When the Bulb requires replacement, the following procedure must be followed.
2. Turn the Power Switch off and disconnect the Power Supply from the electrical power source. Allow the Bulb to cool.

CAUTION: The Bulb operates at temperatures exceeding 500°C. Touching the Bulb before sufficient cool down time is allowed will cause severe burns. Always wear safety eye wear while replacing Bulb.

3. Hold the Lamp/Reflector Assembly Housing securely and loosen the thumbscrew on the Lamp/Reflector Assembly Housing Bracket. Lift the housing off the Mounting Stand and place upside down on a clean work surface.
4. Remove the Glass UV Filter (if installed in the 2000-EC) by removing one Retaining Strap held by two (2) 8-32 x 3/8" button-head screws with a 3/32 hex wrench. If the optional Glass UV Filter is installed, loosen the two (2) 8-32 x 3/8" button-head screws in the remaining Retainer Strap so that the Glass UV Filter can slide out.
5. Reach into the Reflector and grasp the flat area of Bulb at either end.

CAUTION: Always use a soft, clean rag, clean paper towel, or gloves when handling the Bulb. Skin oils left on the Bulb will burn into the quartz, reducing output intensity. If the Bulb is inadvertently touched, clean the Bulb thoroughly with a soft, clean rag and alcohol.

Figure 8.
Bulb in Reflector

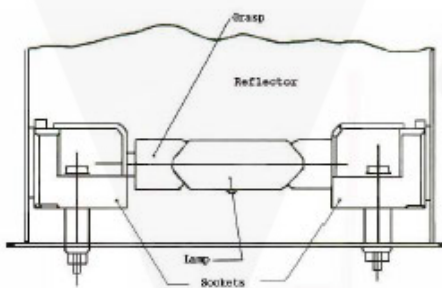

6. Lightly push the Bulb toward the Socket on the opposite end of the Lamp so that the end being grasped can be lifted clear of the Socket (Figure 9).

Contact the professionals at Fiber Optic Center for a quote or to get more details.

focenter.com • 508-992-6464 | (800) 473-4237 • sales@focenter.com

23 Centre Street • New Bedford, MA 02740 USA

Figure 9.
Bulb Removal

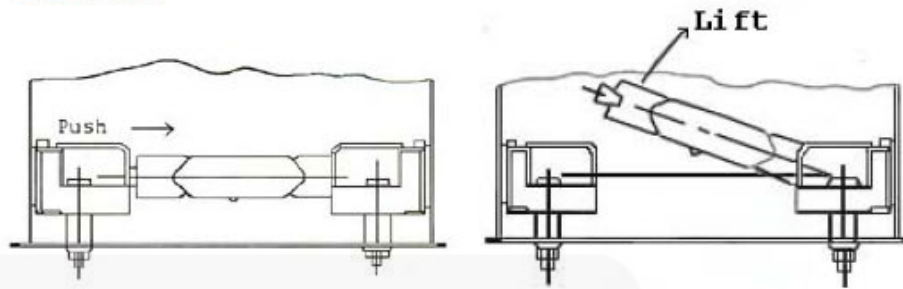

7. Install the new Bulb by following Steps 5, 6, and 7 in the reverse order.

IMPORTANT: Install the Bulb such that the seal dimple on the bulge of the glass is facing towards the Reflector surface. Avoid touching the quartz tube with your fingers.

NOTE: Bulb has no polarity.

8. Record the serial number of the unit and the hour-meter reading in the Bulb History Record.
9. Replace the Lamp/Reflector Assembly Housing on the Mounting Stand by engaging the Mounting Bracket.
10. Secure the thumbscrew when the Lamp/Reflector Assembly Housing is at the proper height.
11. Reconnect the Power Cord to the appropriate power source.
12. Turn the Power Switch on and allow the Lamp to warm up for five minutes before using.

NOTE: If the Lamp does not ignite, refer to the trouble-shooting section of this manual.

Lamp Base Replacement Instructions

1. Turn off the power.
2. Remove the Power Cord and Interconnect Cord from the unit.
3. Remove the Lamp/Reflector Assembly from the Mounting Stand and place it on a clean, flat surface with the Lamp facing up.
4. Remove the Lamp (refer to Lamp Replacement Procedure).
5. Remove the Lamp/Reflector Assembly from the housing by removing the four screws, two on each side, from the Reflector.
6. Remove the two screws from the side of the unit, holding the Igniter in place (located inside a blue fireproof sleeve) and remove from the sleeve.
7. Loosen the screws and remove the wires from the Igniter at locations marked "N" and "La". The black PTFE wire at location "N" will have to be clipped from the Lamp Base Wire and re-stripped.
8. Remove both Lamp Bases and install the new Lamp Bases from the Lamp Base Replacement Kit.

Contact the professionals at Fiber Optic Center for a quote or to get more details.

9. Take one of the Lamp Bases and crimp on a supplied terminal (PN 35202). This wire will be installed in the "La" location on the Igniter.
10. The remaining Lamp Base Wire will be joined with the black PTFE wire using the supplied terminal (PN 35218). This wire will be installed in the "N" location on the Igniter.
11. Place the Igniter back into the blue fireproof sleeve and fasten to the side of the Housing using the two screws that had been removed in Step 6.
12. Place the Reflector back into the Housing and fasten with the four remaining screws.
13. Place the Lamp back into the unit.

Fuse Replacement Procedure

The EC-Series 400-Watt Power Supply utilizes two Line-Input Fuses. These Fuses are external and are located in the Power Cord Receptacle at the rear of the Power Supply Housing. They are 6.25 Amp, slow-blow Fuses.

WARNING! Electrical shock hazard. Exercise extreme care when replacing Fuses. Make sure only qualified personnel perform Fuse replacement and that all Power Switches are off and the Power Cord is unplugged.

Replacing External Fuses

1. Turn the Power Switch on the Power Supply off.
2. Unplug the Power Cord from the electrical source.
3. Unplug the Power Cord from the Power Cord Receptacle at the rear of the Power Supply Housing.
4. Place a small, flat-blade screwdriver into the notch at the top of the Plug Recess and pull the Fuse Cover downwards approximately 70°. The Fuse Retainer should be exposed and should be removed by pulling it straight out (Figure 10).

Figure 10.
Replacing Fuses in the Power Supply



5. Slide out the blown Fuses and replace with new 6.25 Amp, slow-blow Fuses.
- CAUTION:** It is important to replace this Fuse with the same 6.25 Amp rated, slow-blow type Fuse.
6. Slide the Fuse Cover back into the Receptacle until it is fully seated, then rotate the cover upward until it latches.
 7. Install the Power Cord and connect it to the electrical power source.
 8. Turn the Power Switch on.

Contact the professionals at Fiber Optic Center for a quote or to get more details.

Cleaning

Periodically remove and clean the optional Glass UV Filter if installed. Follow Step 5 in the Bulb Replacement Procedure for removal. Clean with any standard glass cleaner or use isopropyl alcohol for heavy deposits. Reinstall the Glass UV Filter by following Step 2 of the Installation Procedure.

NOTE: The optional Glass UV Filter for the 2000-EC loses its ability to transmit UV over time. This is due to “solarization” of the glass caused by the intense UV radiation. Cleaning can extend the useful life of the Filter, but its transmission should be monitored periodically and replaced as necessary.

Failure to regularly clean the Glass UV Filter will result in reduced UV output to the resin being cured, thereby increasing the time required to achieve optimum cure.

Periodically clean the Bulb and Reflector surfaces. A soft, clean cloth and any standard glass cleaner should be used. Heavier deposits may require cleaning with isopropyl alcohol.

CAUTION: Cleaning the Reflector with a rough or dirty cloth will result in a dulled surface, thereby reducing reflectance and decreasing UV output. Use only a soft, clean cloth.

Any uncured resins spilled onto the Flood Lamp can be removed with isopropyl alcohol and a clean cloth.

Preventing Unit Overheating

Dymax EC-Series UV-Curing Flood-Lamp models do not possess an automatic shut-off capability in the event of the Lamp Reflector Assembly overheating. The Ignitor within an EC Lamp Reflector Assembly, under certain conditions, may overheat to a point where the Ignitor itself can melt, char, or smoke if the unit continues to operate while in an overheated condition. Adjacent materials and components, such as fiberglass insulation and insulated wiring, may show heat and/or smoke associated discoloration or degradation. The following checks will reduce the risk of overheating Ignitors within the Lamp Reflector Assembly:

1. Replace Bulbs at the recommended 2,000-hour service intervals, or before the intensity falls outside of the application requirements. A degraded or damaged Bulb increases the risk of arcing, or can create an excessive current draw on the Ignitor which can raise the internal temperature of the Ignitor.
2. Dymax recommends that only Dymax-branded OEM Bulbs be used in the EC Lamp Reflector Assemblies. Some after-market or inferior quality Bulbs are built to different specifications which may deteriorate more rapidly, leading to an increased burden on the Ignitor, and associated internal temperature increase of the Ignitor.
3. Confirm that the Bulb orientation is correct, and has been properly seated into the Lamp Sockets.

A secure Bulb should not move freely in the Lamp Base. Lightly try to move the Bulb laterally, longitudinally, and rotationally to ensure the Bulb contact areas are fully seated with the Socket contacts.

NOTE: Always use a soft, clean lint free towel, clean paper towel, or gloves when handling the Bulb. Skin oils left on the Bulb will burn into the quartz, reducing output intensity. If the Bulb is inadvertently touched, clean the Bulb thoroughly with a soft, clean lint free towel and alcohol. Refer to the user manual enclosed within the unit for complete instructions.

4. Inspect Lamp Sockets for any signs of arcing, physical, or heat-related damage, and replace if needed. Inspect closely, as the Lamp Sockets are ceramic and may have a hairline crack that may not be noticeable from afar.

Contact the professionals at Fiber Optic Center for a quote or to get more details.

focenter.com • 508-992-6464 | (800) 473-4237 • sales@focenter.com

23 Centre Street • New Bedford, MA 02740 USA

On the 5000-EC, the Lamp Socket is partially hidden by the Reflector material. The Reflector may be removed by the 4 Screws on the bottom of the unit to allow for a more detailed inspection.

5. As with any machinery or equipment, general preventive maintenance should be performed to ensure the equipment continues to perform as intended. Wear components, such as Fans and Lamp Socket Assemblies, should be replaced routinely.
 - Lamp Socket Assemblies should be replaced every 4 Bulb changes.
 - Fans should be replaced every 5 years or 50,000 hours of ON time.

For severe duty applications (e.g. units that are running under 24/7 operating conditions, or harsh ambient condition), replacements should be considered every 4 years, or 40,000 hours. |

6. Ensure that the Fan, on any fan-equipped model, is operating while the Lamp is in use.
 - If the Fan is not spinning, check to ensure that all electrical connections to the Reflector Head are secure and the Fan is getting power to run.
 - Confirm that the Fan is free of debris or contamination that could restrict air flow. Visible debris should be cleaned and removed.
 - With the power turned OFF, check to ensure the Fan Blades can rotate freely.
7. For models without Fans, the unit relies on natural convection for cooling. The recommended installation is an upright position (energy emissions facing downward), to allow rising hot air to escape freely. Optional provisions for horizontal mounting can be acceptable, but inverted Lamps should be avoided.

The installation requires unrestricted airflow in accordance to the user manual to minimize/eliminate entrainment and recirculation of hot air.

8. For EC units mounted on Conveyor Systems, ensure that the Conveyor Exhaust Blower is operating and adjusted properly to provide the sufficient air flow and cooling to the Lamps.

Ensure that there is at least 6" of open space around all surfaces of the head, and that airflow is unrestricted to the top and bottom sides.

9. Measure and check the temperature of the EC unit's outside sheet-metal surface to ensure the temperature is in the range of 115°F to 145°F. If the temperature is exceeding this value range, it may be an indication that the unit's operating environment is not suitable, or the equipment requires further inspection of components.

Temperature strips (PN 38694) can be purchased and adhered to the top side of unit if instrumentation to measure directly is not available to the user.

Contact the professionals at Fiber Optic Center for a quote or to get more details.

focenter.com • 508-992-6464 | (800) 473-4237 • sales@focenter.com

23 Centre Street • New Bedford, MA 02740 USA

Troubleshooting

NOTE: Only qualified maintenance personnel should attempt the following procedures.

Problem	Possible Cause	Testing	Corrective Action
Lamp Will Not Ignite or Lamp Flickers, Won't Maintain Operation	Improperly fastened connections	Visually inspect all connections to and from the Power Supply.	Secure all connections.
	Main Line Fuses blown	Remove Fuses from Power Receptacle and check with an Ohmmeter.	Replace Fuses, if defective.
	Corroded Lamp Bases	Visually inspect the Lamp Bases for any signs of corrosion.	Replace the Lamp Bases if corrosion exists (both Lamp Bases should be replaced at the same time).
	Bulb beyond its useful life	Replace the Bulb with a Bulb that is good and re-test unit.	Replace the Bulb if defective (typical Bulb life = 2,000 hours).
	Power Supply Board failed	Check the output voltage on the Power Supply Board. Set the Oscilloscope to: 20 ms/div 100 V/div	Expected value 290-340 V/rms Square Wave. Replace the Power Supply Board if defective.
	Ignitor malfunctioned	Verify open circuit voltage from Ignitor. Set the Oscilloscope to: 50 us/div 1000 V/div	Expected value 4-5 KV ignition pulse superimposed on the square wave. Replace if defective.
Unit Blows Input Fuse	Malfunction in the Power Supply Board	Remove power. Disconnect the Lamp/Reflector Assembly from the Power Supply. Replace the Fuse. Apply power. If a Fuse blows, the Power Supply is defective.	Replace the Power Supply Board.
UV Intensity Appears to Be Low	Bulb beyond its useful life	Use a Radiometer (ACCU-CAL™ 50) to measure actual output intensity. Consult manual for proper output.	Replace the Bulb if beyond the useful life (typical life = 2,000 hours).
	Quartz Envelope on Bulb contaminated	Visually inspect the Bulb for signs of contamination (Quartz Envelope must be free from any contamination).	Clean the Bulb with a soft, lint-free cloth and isopropyl alcohol. Bulb may have to be replaced if contamination is burned into Quartz Envelope.
	Surfaces of Reflector may be contaminated	Examine reflector surface for contaminants (should be a clean, shiny surface).	Clean the Reflector with a soft, lint-free cloth and isopropyl alcohol or an equivalent.
	Optional Glass UV Filter contaminated (2000-EC only)	Examine the Glass UV Filter for signs of contamination.	Clean the Glass UV Filter with a soft, lint-free cloth and isopropyl alcohol or an equivalent.

Contact the professionals at Fiber Optic Center for a quote or to get more details.

Spare Parts and Accessories

Item	Part Number
Fuses	
Fuse, F 6.25 Amp	35141
Personal Protection Equipment	
Protective Goggles — Clear	35612
Protective Goggles — Gray	35285
Lamps	
Lamp, Metal Halide 400 Watt UV (Standard)	38560
Lamp, Mercury Vapor 400 Watt UV (Optional)	36970
Lamp, Visible 400 Watt (Optional)	36658
Lamp Base Replacement Kits	35979
Miscellaneous	
Optional Fan Assembly (2000-EC, 1200-EC)	38300
Optional Glass UV Filter (2000-EC Only)	35899
Power Switch	36288
Repair Kit, EC Silver Power Supply	41096
Stands	
Mounting Stand Kit for the 5000-EC	38289
Mounting Stand Kit for the 1200-EC & 2000-EC	38290

Contact the professionals at Fiber Optic Center for a quote or to get more details.

focenter.com • 508-992-6464 | (800) 473-4237 • sales@focenter.com

23 Centre Street • New Bedford, MA 02740 USA

Accessories

Several optional accessories are available to enhance efficiency and operation of Dymax EC-Series UV Light-Curing Flood Lamps.



UV Radiometer (PN 39561)

Dymax offers an ACCU-CAL™ 50 for monitoring the UV intensity of the EC-Series Flood Lamps. This Radiometer is calibrated to measure UVA output (320-390 nm) wavelength.

Features include:

- Auto ranging, digital readout (1.0 to 40,000 mW/cm²)
- Measures light intensity in mW/cm²
- Powered by AA batteries (included)
- Stores in molded plastic case (included)



Top Ventilation Kit for 1200-EC and 2000-EC Lamps (PN 38300)

The standard Dymax EC-Series Lamps employ convection cooling. In situations where supplemental cooling is required or removal of curing vapors from under the Lamp/Reflector Assembly Housing is desired, an optional Ventilation Kit is available. The kit can be a fixed metal skirt that fits on either the rear or the top of the Lamp/Reflector Assembly Housing. The top fan skirt for the 2000-EC and 1200-EC Lamps is provided with the purchase of a Shutter.

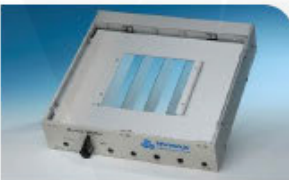

Manual Louvered Shutter (PN 35572) & Electric ZIP™ Shutter (PN 37863)

Safety Enhancing Timing Devices

The Dymax ZIP™ Shutter (retractable) and Manual Louvered Shutter allow timed light exposure, reduce heat on work area surfaces, and reduce operator exposure to UV light.



Light Shield (PN 41175)

The Light Shield is a complete enclosure with 360° of shielding. It is constructed so the operator can safely observe objects in the curing process through a window in the front door.

Contact the professionals at Fiber Optic Center for a quote or to get more details.

focenter.com • 508-992-6464 | (800) 473-4237 • sales@focenter.com

23 Centre Street • New Bedford, MA 02740 USA

Specifications

General Specifications

Table 1.
General Specifications



Property	Specification		
	1200-EC	2000-EC	5000-EC
Model			
Reflector Housing Dimensions, W x D x H	10.5" x 9.0" x 7.5" [26.7 cm x 22.9 cm x 19.1 cm]	10.5" x 9.0" x 7.5" [26.7 cm x 22.9 cm x 19.1 cm]	6.75" x 6.75" x 8.0" [17.2 cm x 17.2 cm x 20.3 cm]
Weight	3.4 lbs. [1.5 kg]		2.7 lbs. [1.2 kg]
Typical Initial Output Intensity at UV-A* (365 nm)	400 mW/cm ²	105 mW/cm ²	225 mW/cm ²
Overall Unit Dimensions, Approx.	16" x 12" x 19" [40.6 cm x 30.5 cm x 48.3 cm] W x D X H		
Power Supply Dimensions, Approx.	16" x 12" x 4.25" [40.6 cm x 30.5 cm x 10.8 cm] W x D X H		
Bulb Life	2,000 hours (warranted)		
Hour Meter	99,999.9 hours (non-resettable)		
Bulbs	38560 400 Watt, metal halide (standard) 36970 400 Watt, mercury vapor (optional) 36658 400 Watt, visible (optional)		

* 1200-EC: Intensity 4.5" from bottom edge of lamp/reflector assembly housing with the beam focused; 5000-EC: Intensity 3" below bottom edge of lamp/reflector assembly housing. All measured with an ACCU-CAL™ 50 UV Radiometer calibrated and traceable to NIST.

Contact the professionals at Fiber Optic Center for a quote or to get more details.

focenter.com • 508-992-6464 | (800) 473-4237 • sales@focenter.com

23 Centre Street • New Bedford, MA 02740 USA

Figure 11.
EC Flood Lamp Spectral Output –400-Watt Flood Bulbs

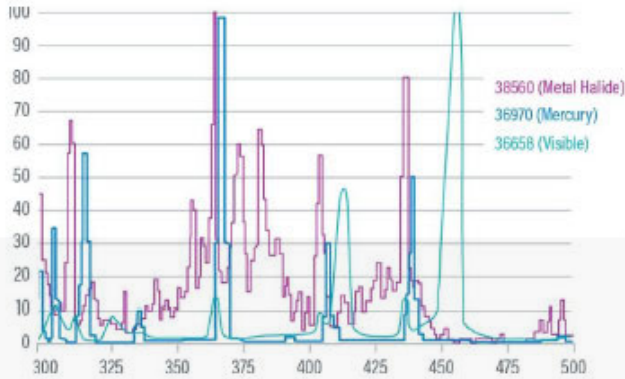

Electrical Specifications

Table 2.
Electrical Specifications

Property	Specification
Power Supply	
Power Outage Range	Factory set to 395 Watts
Operating Temperature	0 to 50°C
Storage Temperature	-20 to 80°C
Operating Humidity	0-80% relative humidity, non-condensing
Flood Lamps	
Main Voltage	90 - 264 VAC
Line Frequency	47-63 Hz
Current Consumption (max)	@115 VAC 8A @230 VAC 4A
Inrush Current (max)	30A
Electrical Regulation	+/- 2.5% for effects of load, line, temperature
Output Protection	Short circuit and overload protected
Auxiliary DC Outputs	+24V, 1A available for lamp housing fan and shutters +/- 24V, ~0.5A and +6V unregulated

Contact the professionals at Fiber Optic Center for a quote or to get more details.

Definition of Terms

Brightness, also known as **Luminance** - Description of energy in the visible region of the spectrum (approximately from 400 to 700 nm) and recorded in photometric units. "**Intensity**" (see below) of visible light energy is called Illuminance.

Dose - irradiance integrated over time, or Irradiance (W/cm²) x Time (s) = Dose (Joules/cm²).

NOTE: Watt is the power that gives rise to the production of energy at the rate of 1-joule (J) per second (s).

Flood Lamp System - set of components arranged to generate, collect, condition, and direct UV radiant energy to perform curing of engineering adhesives, coatings, and inks within a safe and controlled process. It includes a lamp housing and power supply and may also include a shutter, workstation, UV enclosure, Dymax light shield, and/or accessories.

Intensity - a measure of light energy over the unit of surface area (usually the surface at the specified working distance from the bottom of the reflector housing) in W/cm² or mW/cm².

Lamp - light source (bulb or burner) generating ultraviolet, visible, and infrared radiant energy from burning matter stimulated by electrical power conditioned by a proper power supply which is an integral part of a lamp. A light source is usually placed into a reflector (of various geometry) to increase light source efficiency by collecting and directing radiant energy of selected spectra (for a given curing process).

Luminance - Luminous flux (energy of visible light) incident per unit area, and measured in Lx (lux) or Lumen/cm².

Ozone - oxidizing agent (O³) produced by the action of ultraviolet radiant energy (below 185 nm) or electrical corona discharge of oxygen on air.

Ultraviolet (UV) - The invisible region of the spectrum just beyond the violet end of the visible region. Wavelength ranges in general from 1.0 to 400 nm. Dymax lamps (bulbs) do not radiate energy in deep ultraviolet; there are very minute amounts below 220 nm and practically nothing can be sensed below 200 nm. This is due to the use of ozone-blocking quartz bulb envelope (See Ozone).

Ultraviolet is used beneficially in various fields of industry and medicine. In order to standardize light sources used in medicine, the International Congress on Light, in Copenhagen in 1932, recommended dividing the ultraviolet spectrum into three spectral parts:

- **Ultraviolet A (UV-A)** - UV of long wavelength from within approximately 400 to 320 nm of the spectral band (4000 to 3200Å) - predominately produced by Dymax flood lamps.
- **Ultraviolet B (UV-B)** - UV of medium wavelength from within approximately 320 to 280 nm - Dymax flood lamps produce some amount of their energy within this bandwidth.
- **Ultraviolet C (UV-C)** - UV of short wavelength below 280 nm (we say from 280 to 200 nm) - a large amount of this energy is present in the sunlight.

OSHA 1910.145: "Regulation of Accident prevention Signs and Tags" defines the following headers as:

- **WARNING** - is used when there is a hazardous situation that has some probability of severe injury.
- **CAUTION** - is used to indicate a hazardous situation that may result in minor or moderate injury.
- **NOTICE** - is used to convey a message related directly or indirectly to the safety of personnel, or protection of property.

Contact the professionals at Fiber Optic Center for a quote or to get more details.

focenter.com • 508-992-6464 | (800) 473-4237 • sales@focenter.com

23 Centre Street • New Bedford, MA 02740 USA

USER GUIDE

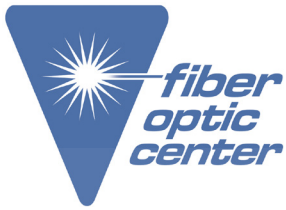

Manufacturer:

Dymax

Product Name:

Dymax UV Protective Safety Goggles - Gray Lens

Manufacturer Part Number:

35285

▶ [Click here for more details on the Dymax UV Protective Safety Goggles - Gray Lens](#)

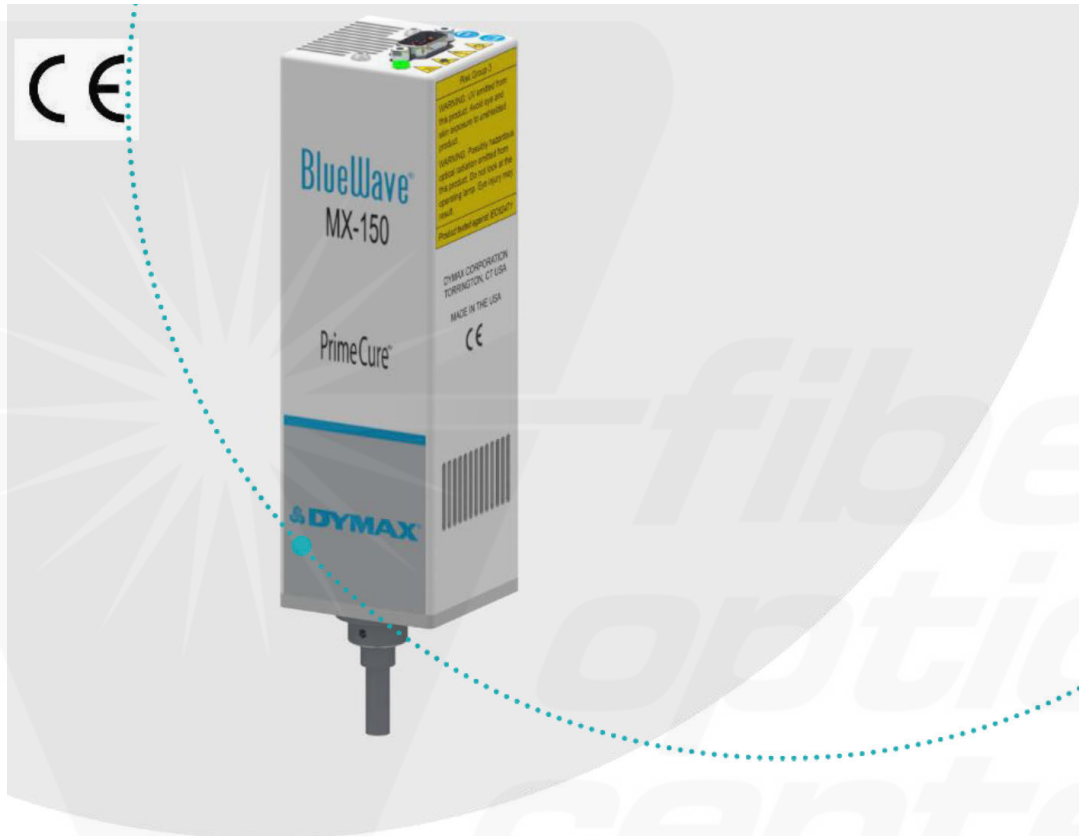

BlueWave® MX-150 LED Spot-Curing Emitters

User Guide

[>> Return to Page 1](#)

Contact the professionals at Fiber Optic Center for a quote or to get more details.

focenter.com • 508-992-6464 | (800) 473-4237 • sales@focenter.com

23 Centre Street • New Bedford, MA 02740 USA

Product data subject to change without notice. FOC last update 6/19/26

Introduction

This guide describes how to set up, use, and maintain BlueWave® MX-150 emitters safely and efficiently.

Intended Audience

This user guide is meant for experienced process engineers, technicians, and manufacturing personnel.

Safety



WARNING! Under NO circumstances should the interconnect cable from the controller to the LED emitter be connected or disconnected while power to the unit is on. This procedure is usually called “hot swapping” and should not be performed as it could cause damage to the controller or the emitter. Always power down the equipment before disconnecting or connecting any of these devices.



WARNING! If you use this UV LED light source without first reading and understanding the information in the UV Light Safety Guide, SAF001, injury can result from exposure to high-intensity light. To reduce the risk of injury, please read and ensure you understand the information in that guide before assembling and operating the Dymax UV LED light source.



Specific Safety statements for this device:

This device falls under IEC 62471 Risk Group 3 for UVA and Blue Light Emissions:

WARNING. UV emitted from this product. Avoid eye and skin exposure to unshielded products.

WARNING. Possibly hazardous optical radiation emitted from this product. Do not look at operating lamp. Eye injury may result.

>> [Return to Page 1](#)

Contact the professionals at Fiber Optic Center for a quote or to get more details.

focenter.com • 508-992-6464 | (800) 473-4237 • sales@focenter.com

23 Centre Street • New Bedford, MA 02740 USA

Product Overview

Description of BlueWave MX-150 Emitters

- When paired with a MX-series controller, BlueWave MX-150 emitters function as a high-intensity spot-curing system. The system can be set up in many configurations and can be used with a lightguide if needed.
- The BlueWave MX-150 emitter is air cooled using an axial fan.
- The BlueWave MX-150 emitter can be mounted using one of two hole-patterns in the housing body.

Figure 1.
BlueWave MX-150 Emitter



>> Return to Page 1

Contact the professionals at Fiber Optic Center for a quote or to get more details.

focenter.com • 508-992-6464 | (800) 473-4237 • sales@focenter.com

23 Centre Street • New Bedford, MA 02740 USA

Product data subject to change without notice. FOC last update 6/19/26

Unpacking

Upon arrival, inspect all boxes for damage and notify the shipper of box damage immediately. Open each box and check for equipment damage. If parts are damaged, notify the shipper and submit a claim for the damaged parts.



WARNING! *Until the BlueWave® MX-150 emitter is attached to a controller via the interconnect cable it is susceptible to ESD damage, handle according to ESD standards using a ground strap and do not touch exposed connector pins.*

The parts below are included in every package/order.

Parts Included

LED Emitter

- BlueWave MX-150 LED Emitter Assembly
- 5-mm Lightguide Simulator
- User Guide

Installation

The BlueWave MX-150 emitter is part of a MX-series curing system and requires connection to a controller via an interconnect cable for proper operation.

Important Information

- Do not connect any components while power is applied.
- Mount the BlueWave MX-150 emitter to a rigid support, such as the emitter stand PN 42390, prior to connecting the interconnect cable to prevent handling damage.
- Always keep the LED area covered by a lightguide, rod lens, or lightguide simulator. Assure that FOD cannot flow into the LED area.

[>> Return to Page 1](#)

Contact the professionals at Fiber Optic Center for a quote or to get more details.

focenter.com • 508-992-6464 | (800) 473-4237 • sales@focenter.com

23 Centre Street • New Bedford, MA 02740 USA

Product data subject to change without notice. FOC last update 6/19/26

Mounting/Connections

- Each emitter has two sets of M3 x 0.5 mm holes (Figure 1) that align with Dymax stands and holders.
- When connecting the emitter to the controller, ensure proper strain relief to prevent pinching or kinking of the interconnect cable.
- The cooling air intake on top of unit must be free flowing, do not cover.
- Exhausting air on sides must be given at least 1 mm (0.04") of clear space to obstructions for safe use.

Figure 2.
Bluewave MX-150 Emitter Dimensions

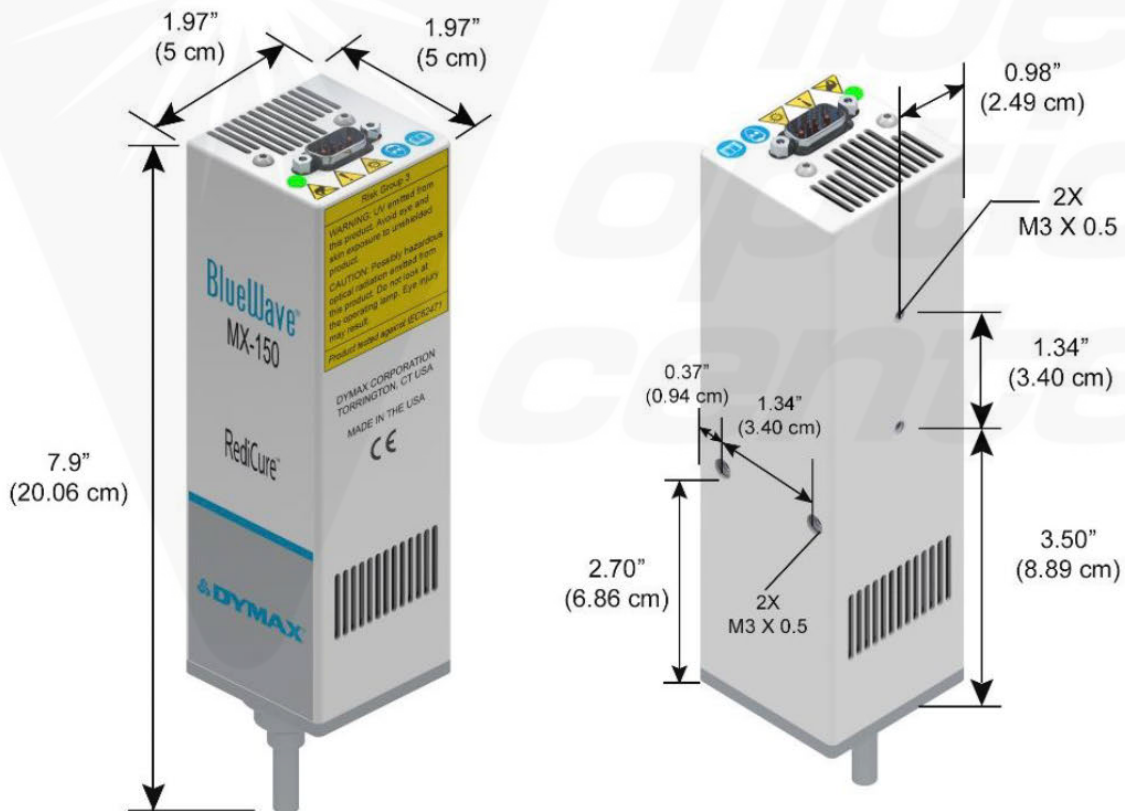

>> Return to Page 1

Contact the professionals at Fiber Optic Center for a quote or to get more details.

focenter.com • 508-992-6464 | (800) 473-4237 • sales@focenter.com

23 Centre Street • New Bedford, MA 02740 USA

Product data subject to change without notice. FOC last update 6/19/26

Troubleshooting & Maintenance

Problem	Possible Cause	Corrective Action
BlueWave MX-150 LED does not produce light	LED intensity adjustment set to 0% or too low	Increase LED intensity setting.
	LED cycle time is set to 0 seconds	0 Seconds sets manual mode and requires a trigger.
	Interlock is open	Verify interlock jumpers are in place. Verify PLC command structure for PLC mode.
	Interface cable connections loose or damaged	Check connections and condition of interface cable.
	Trigger setting not matched to input	Trigger setting on admin screen should match the desired input trigger channel.
	LED head is not connected to the correct port/channel	Verify that the head is connected to the desired port/channel.
BlueWave MX-150 LED suddenly stops producing light	Lightguide not inserted	Ensure the lightguide simulator or any lightguides installed with the unit are fully seated into the Wolf connector.
	Over-temperature shutdown was triggered	Verify alarms.
	Footswitch defective	Activate unit using the front control panel. Replace the footswitch if the unit operates from the front control panel.
	Interlock is open	Verify interlock jumpers are in place. Verify PLC command structure for PLC mode.
BlueWave MX-150 LED provides only low-intensity light	LED intensity adjustment set to minimum	Increase LED intensity setting on admin settings or I/O input for PLC mode.
	Contaminated/dirty lens optics	Clean the surface of the lens.

>> [Return to Page 1](#)

Contact the professionals at Fiber Optic Center for a quote or to get more details.

focenter.com • 508-992-6464 | (800) 473-4237 • sales@focenter.com

23 Centre Street • New Bedford, MA 02740 USA

Product data subject to change without notice. FOC last update 6/19/26

Product Cleaning and Care

- Product cleaning is limited to wiping the outside of the product with a damp cloth. Do not soak. Isopropanol Alcohol or household cleaners may be used for cleaning the product.
- Keep the LED array free from dust and debris (FOD). Contamination can lead to loss of performance or failure. Protect the LED array by always keeping a light guide, rod lens, or light guide simulator installed.
- Do not insert tools or cleaning devices into the LED opening, and do not attempt to clean the LED array. Disruption from touching, and exposure to cleaning materials can damage the array.
- Do not use compressed air to remove particle debris inside the emitter as it may damage the LED array or the high-speed cooling fan.

Spare Parts

Item	Part Number
5-mm Lightguide Simulator	36987

>> [Return to Page 1](#)

Contact the professionals at Fiber Optic Center for a quote or to get more details.

focenter.com • 508-992-6464 | (800) 473-4237 • sales@focenter.com

23 Centre Street • New Bedford, MA 02740 USA

Product data subject to change without notice. FOC last update 6/19/26

Compatible Devices

Item	Part Number
Controllers	
BlueWave® MX Series 2-Channel Controller/Power Supply - US	43185
BlueWave® MX Series 4-Channel Controller/Power Supply - US	43182
Emitters	
BlueWave MX-150, VisiCure® (405 nm)	42338
BlueWave MX-150, PrimeCure® (385 nm)	42337
BlueWave MX-150, RediCure® (365 nm)	42336
BlueWave MX Series System Components	
Interconnect Cable Assembly - 12 Inches	43453
Interconnect Cable Assembly - 2 meter	42287
Interconnect Cable Assembly - 5 meter	42889
Extended Interconnect Cable - 10 meter*	43010
Extended Interconnect Cable - 20 meter*	43011
5-mm Lightguide Simulator	36987
5-mm x 1,000-mm Liquid Lightguide	35102
3-mm x 1,000-mm Bifurcated Guide (5-mm Rod)	37043
Adjustable Focusing Lens	41148
Radiometer	
ACCU-CAL™ 50-LED Radiometer	40505
Stands	
Array Stand	43070
Single Emitter Mounting Stand	42390
Dual Emitter Mounting Bracket for MX Controller	60868
Personal Protection Equipment	
Three-Sided Acrylic Shield	41395
Protective Goggles — Green**	35286
Protective Goggles — Gray (standard model included with unit)**	35285
Face Shield**	35186

* Intended for machine installations only.

>> [Return to Page 1](#)

Contact the professionals at Fiber Optic Center for a quote or to get more details.

focenter.com • 508-992-6464 | (800) 473-4237 • sales@focenter.com

23 Centre Street • New Bedford, MA 02740 USA

Product data subject to change without notice. FOC last update 6/19/26

Specifications



Property	Specification		
Emitter	RediCure	PrimeCure	VisiCure
Output Frequency	365 nm	385 nm	405 nm
Typical Intensity Output*	24 W/cm ²	38 W/cm ²	36 W/cm ²
Emitter Dimensions (W x D x H)	1.97" x 1.97" x 7.9" [5 cm x 5 cm x 20.06 cm]		
Weight	1.4 lbs. [0.64 kg]		
Unit Warranty	1 year from purchase date		
Operating Environment	10 to 40°C (50°F to 104°F), 0-80% relative humidity, non-condensing		

* Measured using an ACCU-CAL™ 50-LED radiometer with a 5-mm lightguide at a distance of 0 mm.

Figure 3.
BlueWave MX Series Spectral Output

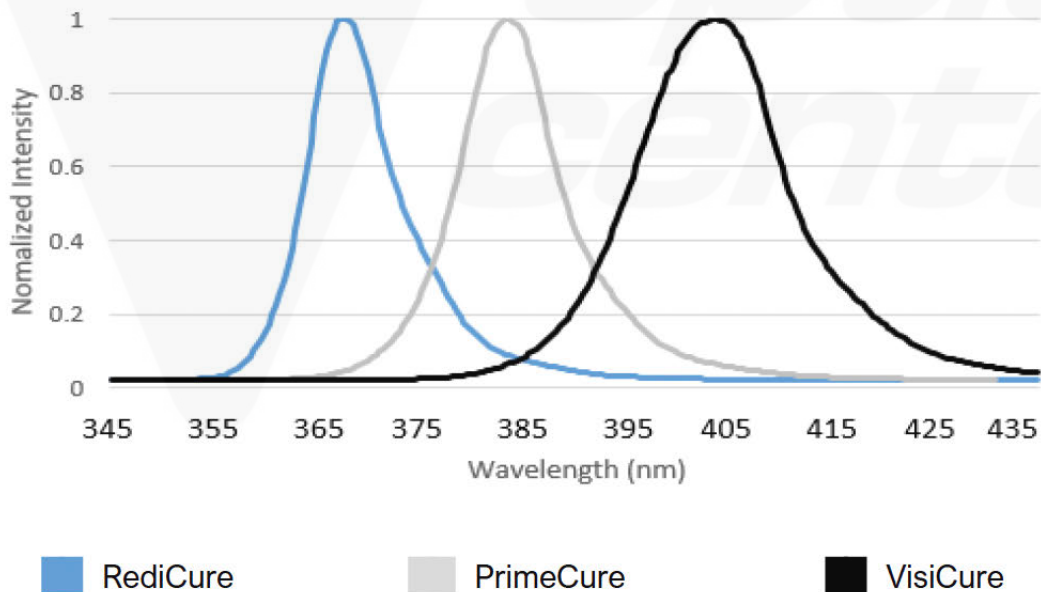

>> Return to Page 1

Contact the professionals at Fiber Optic Center for a quote or to get more details.

focenter.com • 508-992-6464 | (800) 473-4237 • sales@focenter.com

23 Centre Street • New Bedford, MA 02740 USA

Product data subject to change without notice. FOC last update 6/19/26

Declaration of Conformity

Figure 4.
Declaration of Conformity - CE



EU Declaration of Conformity

Manufacturer:
Dymax Corporation
318 Industrial Lane
Torrington CT 06790, USA

Product description:
Model name(s):

BlueWave ® MX-150 LED Spot-Curing System
BlueWave ® MX-150 LED Emitter

This product complies with the following relevant Union Harmonization Legislation:

Applicable EU Directives:
Electromagnetic Compatibility Directive(2014/30/EU)

Low Voltage Directive(2014/35/EU)

RoHS Directive 2011/65/EU (2015/863)

Applicable Harmonized Standards:
EN55011:2016/A1:2017/A11:2020
EN 61000-3-2:2014 Class A
EN 61000-3-3:2013
EN 61326-1:2013
EN 61010-1:2010 AMD1:2019

EN IEC 63000:2018

Declaration:
This declaration of conformity is issued under the sole responsibility of the manufacturer.
Signed for and on behalf of:

 3/26/2025 Torrington, CT
Name Date Location

CE

Authorized Signatory:
Robert Gallagher
Engineering Manager, Equipment
Dymax Corporation
Torrington CT., USA

>> Return to Page 1

Contact the professionals at Fiber Optic Center for a quote or to get more details.

focenter.com • 508-992-6464 | (800) 473-4237 • sales@focenter.com

23 Centre Street • New Bedford, MA 02740 USA

Product data subject to change without notice. FOC last update 6/19/26

© 2019-2025 Dymax Corporation. All rights reserved. All trademarks in this guide, except where noted, are the property of, or used under license by Dymax Corporation, U.S.A.

Please note that most curing system applications are unique. Dymax does not warrant the fitness of the product for the intended application. Any warranty applicable to the product, its application and use is strictly limited to that contained in Dymax standard Conditions of Sale published on our website. Dymax recommends that any intended application be evaluated and tested by the user to ensure that desired performance criteria are satisfied.



[>> Return to Page 1](#)

Contact the professionals at Fiber Optic Center for a quote or to get more details.

focenter.com • 508-992-6464 | (800) 473-4237 • sales@focenter.com

23 Centre Street • New Bedford, MA 02740 USA

Product data subject to change without notice. FOC last update 6/19/26