



Manufacturer:
Phenix Fiber Optics

Product Name:
Phenix Fibersect MT APC (pre-angled, 8°) Ferrule Adapter

Manufacturer Part Number:
PNX-AF-MTAPC

▶ [Click here for more details on the Phenix Fibersect MT APC \(pre-angled, 8°\) Ferrule Adapter](#)

Introduction

The Phenix fibersect.multi® cuts the epoxy and fiber protruding from the face of the ferrule during connector installation. Suitable adapters are available for bare ferrules and for fully assembled connectors. Single and multi-fiber ferrule and connector adapters are discussed below.









Cut Distance Adjustment

The cut distance from the face of the ferrule is adjusted by rotating the Adjusting Ring. A tool is provided that engages the two holes in the ring to facilitate rotation. Adapters are shipped with the cut distance adjusted to ~200 µm. Rotate clockwise to cut closer to the face; rotate counterclockwise to cut further away. Marks along the adapter ring perimeter represent increments of 25 µm. Any distance (0 to 600 µm+) can be set. Always change the cut distance in small steps and under controlled conditions to minimize the chance of cutting into the ferrule. The saw will not be noticeably damaged if the ferrule is accidentally cut, but will wear prematurely if done repeatedly. If the ferrule is cut, adjust the adapter to increase cut length to avoid continued saw wear.

Adapter Orientation Adjustment

After adjusting for cut distance, adjust the rotational orientation of the adapter, as required and described below.

Orientation Required

		MT 0° MT 8°	Use the included Orientation Adjust tool to ensure that the ferrule slot is horizontal with the engraved arrow pointed down.
		LC-APC SC-APC	Insert a connector and use it to rotate the adapter until the connector's latch is up.
		LC-D	Rotate the adapter until one connector is directly above the other with their latches pointed to the right.
		FC-APC	Insert a connector and use it to rotate the adapter until the key slot is pointing up.
		MDC MDC-J	Use the adapter extension to rotate the adapter so the ferrule holes are horizontal with the extension below the ferrule holes.

Contact the professionals at Fiber Optic Center for a quote or to get more details.

focenter.com • 508-992-6464 | (800) 473-4237 • sales@focenter.com

23 Centre Street • New Bedford, MA 02740 USA

Product specifications and data are subject to change without notice.



Manufacturer:
Phenix Fiber Optics

Product Name:
Phenix Fibersect MT APC (pre-angled, 8°) Ferrule Adapter

Manufacturer Part Number:
PNX-AF-MTAPC

▶ Click here for more details on the Phenix Fibersect MT APC (pre-angled, 8°) Ferrule Adapter

Orientation Recommended



LC
SC

Insert a connector and use it to rotate the adapter until the connector's latch is up. The cut will be parallel to the ferrule face in any orientation, but this will make it more convenient to insert.

Orientation Not Necessary

All adapters shown here do not require any adjustment and will cut parallel to the face of the ferrule in any orientation.

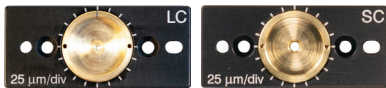

LC Ferrule
SC Ferrule

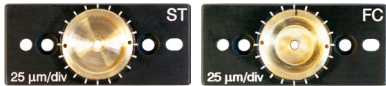

ST Connector
FC Connector

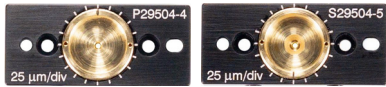

P29504-4
S29504-5

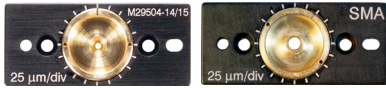

M29504-14/15
SMA

Other Recommendations

Before inserting the connector or ferrule, ensure that bare fiber protruding from the face of the ferrule is no more than 10 mm. A longer length will result in broken fibers. A length of 6 mm or less is recommended to minimize breakage during handling. For best results, ensure that the bare fiber is completely surrounded and supported by epoxy where the cut occurs. Because of the smaller bead of epoxy used for single fibers, a cut close to the ferrule face may be necessary (20 μm to 80 μm). The epoxy should be as fully cured/hardened as possible to provide strong support to the fiber as it is being cut.

Contact the professionals at Fiber Optic Center for a quote or to get more details.

focenter.com • 508-992-6464 | (800) 473-4237 • sales@focenter.com

23 Centre Street • New Bedford, MA 02740 USA

Product specifications and data are subject to change without notice.